



ADTECH

Analog-Digital Technology, Inc.

95 Mt. Read Blvd Suite 149

Rochester, New York 14611 USA

Phone 1.585.698.1845 Fax 1.585.697.0445

FDX 250

Two-Wire Isolated Frequency Transmitter Instruction Manual

1.0 INTRODUCTION

These instructions refer to the above model. Supplementary sheets are attached if the unit has special options or features. For detailed specifications, see page 4 or refer to the Data Bulletin. All ADTECH instruments are factory calibrated and supplied with a label detailing the calibration. Adjustments are normally not necessary. A simple check should be performed to verify calibration before installation to ensure that it matches the field requirement.

2.0 GENERAL DESCRIPTION

The ADTECH Model FDX 250 Isolated Two-Wire Frequency Transmitter provides high accuracy conversion of frequency or pulse rate inputs to a standard 4-20 ma dc process signal.

The primary features of the FDX 250 are:

- Wide range - 0-30Hz to 0-30KHz - switch selectable.
- Field adjustable via internal switch and front potentiometers.
- Crystal controlled time base.
- High accuracy, repeatability, and ambient effect stability.
- Universal input configuration; accepts pulse (including TTL), contact or AC waveform from 10mv to 100V RMS.
- Sensitivity and Hysteresis adjustments for the most demanding signals.
- Built in adaptive digital filtering for improved contact bounce and signal noise immunity.
- RFI Resistant.
- NO INTERACTION of ZERO and SPAN.
- Small size—only 1" w x 3.1" h x 3.6" d.
- Options for NEMA housings, SNAP TRACK and surface mounting.

3.0 INSTALLATION

The instrument is supplied in a non-metallic general purpose DIN rail mount enclosure as standard. NEMA 4 and 7 enclosures are optionally available. Installation area/location must agree with the supplied instruments including operating temperature and ambient conditions. For detailed mounting and installation information refer to page 4 inside.

Electrical Connections

The wire used to connect the instrument to the control system **Input / Output** should be twisted pair(s) and sized according to normal practice. Shielded cable is not normally necessary (if used, the shield must be grounded at the input of the ADTECH instrument and left floating at the sensor).

A six position compression terminal block is provided for the I/O and power connections. A housing ground terminal is not required due to non-metallic housing.

Controls

Instrument controls consist of the following:

- A 16 position major range switch (inside).
- Four multiturn potentiometers; ZERO, SPAN, SENSITIVITY and HYSTERESIS controls.

The four multiturn controls are accessible in front of the instrument for ease of adjustment.

4.0 MAINTENANCE

These instruments are electronic and require no maintenance except periodic cleaning and calibration.

If the unit appears to be mis-operating, field wiring and/or associated circuits should be checked. MOST problems are traced to these areas.

If the problem appears to be the instrument, it may be checked as installed or removed for a bench check as detailed in sections 6.0 and 7.0.

5.0 CONNECTIONS

Standard connections are shown below and on the instrument face plate, Data Bulletin or on attached supplementary sheets.

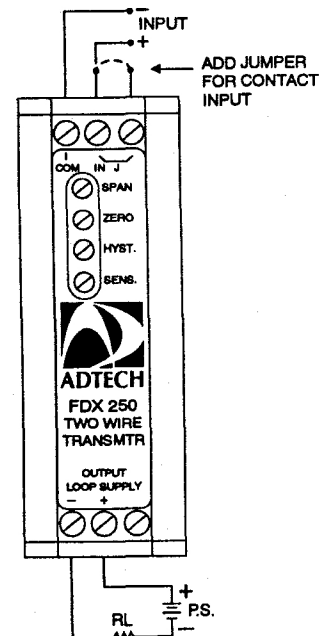

NOTE: For contact input connect a jumper as shown dotted.

6.0 CONFIGURATION

All ADTECH units are factory calibrated per P.O. instructions. Usually, a complete recalibration is not required unless you want to change input type, or the range of the unit. A calibration sticker located on the unit identifies the model number, calibration and options present.

- A. For a recalibration to the same input range proceed to 6.1. For calibration to a new range, open the instrument case to gain access to the pc-boards.
- B. From Table 1, adjust the 16 position switch SW1 so that the frequency range is just higher than the maximum input frequency signal.
- C. Close the case and proceed to 6.1.

6.1 CALIBRATION

- A. Make sure the unit I / O wiring is properly connected and that the correct power source per the label is also connected. The instrument must be at normal power for a minimum of 2 minutes before proceeding to B.
- B. The input signal source must be adjustable from 0 to 100% in steps of 10% or at least 25%. The source should be either precalibrated or an accurate meter must be used to monitor the input.
- C. The output may be monitored as a current or as a voltage across a resistor shunt e.g. 1-5 Vdc across 250 ohms.
- D. Under normal conditions only one input control is required to provide the proper input threshold.
 1. If the minimum input signal level is 1 volt or less, turn the SENSITIVITY control fully clockwise. You will only need adjust the HYSTERESIS for proper operation.
 2. If the minimum input signal level is greater than 1 volt, turn the HYSTERESIS control fully clockwise. Only the SENSITIVITY control is required for proper operation.
- E. Adjust the input signal to the minimum input voltage, and a frequency about mid-scale. Adjust the HYSTERESIS control if the minimum input signal level is 1 volt or less (SENSITIVITY control if the input signal level is greater than 1 volt) to the point where the unit just starts operating. (The output will be about mid-scale.) Give the adjustment an additional 1/4 to 1/2 turn to allow for input signal variations.
- F. With 0% input (or the input shorted) adjust the ZERO control for 4.00 ma to the desired accuracy.
- G. With a 100% input signal at the operating voltage level, adjust the SPAN control for 20.00 ma to the desired accuracy.
- H. Repeat steps F and G until the readings remain within desired calibration accuracy ($\pm 0.1\%$ span).
- I. Check the instrument at the 25-50-75% input settings for linearity.

7.0 FIELD TROUBLE SHOOTING GUIDE

This section offers a simple, first level trouble-shooting aid for an apparent instrument malfunction.

SYMPTOM

CORRECTIVE ACTION

No output

1. Check the input and output connections carefully.
2. Check that the power supply polarity is correct and that the output loop power is present on the indicated terminals.
3. Check that the input source is correct and that it changes magnitude between zero and full scale values when so adjusted.
4. Make sure the output loop is complete and that the correct meter range is selected.

All external checks are complete. Problem seems to be internal.

Troubleshooting beyond the above may be difficult without special equipment. We do not recommend attempting repair of the unit in the field. ADTECH offers a very responsive repair policy. Contact the factory at 716-383-8382 or FAX 716-383-8386.

8.0 TABLES

INPUT TABLE 1

SWITCH POSITION	FREQUENCY RANGE HZ
F	30,000
E	15,000
D	7,500
C	3,750
B	1,875
A	937.5
9	468.8
8	234.4
7	117.2
6	58.59
5	29.30

Note: J1 has a permanent position A

*Select the frequency range that is just equal to or higher than the desired input full scale.

PCB - LAYOUT

COARSE SELECT

SENS.
HYST.
ZERO
SPAN

INPUT PCB

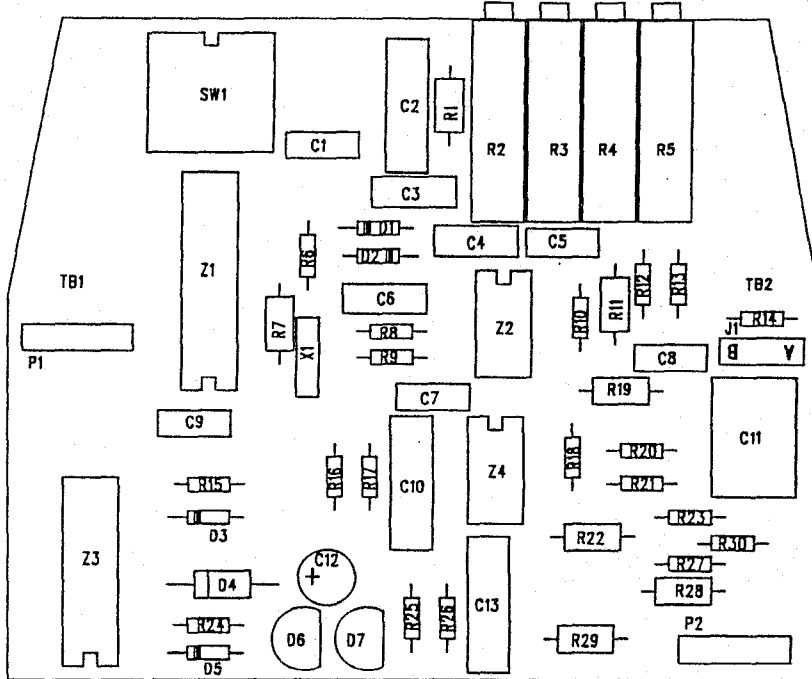

OUTPUT PCB

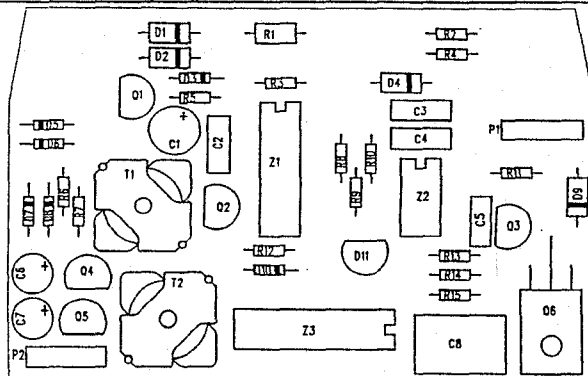

NOTE: All components shown may not be required by this model.

9.0 SPECIFICATIONS

INPUT/OUTPUT

INPUT SIGNALS

- a. Voltage (Amplitude): 10 mv to 100 vrms (0-5 KHz)
50 mv to 50 vrms (5 KHz to 30 KHz)
- b. Contact: Dry, 2 ma @ 24 vac rating
- c. Frequency Range: 0-30 Hz to 0-30 KHz Full Scale
- d. Major Range Switch provides 11 discrete ranges with the ZERO control adjustable $\pm 10\%$ of output and the SPAN control adjustable from 50% to 100% of the major range selected

OUTPUT SIGNAL

4-20 ma dc

OUTPUT LOOP DRIVE CAPABILITY

$$R(\text{ohm}) = \frac{(V \text{ supply} - V \text{ minimum}) 1000}{I \text{ out max. ma}}$$

V minimum = 8.0 vdc

I out	4 - 20 ma			
V supply	12	24	36	42
R (ohm)	200	800	1400	1700

PERFORMANCE

- a. **Calibrated Accuracy:** $\pm 0.1\%$
- b. **Independent Linearity:** $\pm 0.02\%$ maximum,
 $\pm 0.01\%$ typical
- c. **Repeatability:** $\pm 0.005\%$ maximum; $\pm 0.002\%$ typical

- d. **Zero TC:** $\pm 0.01\%$ of span max/ $^{\circ}\text{C}$
- e. **Span TC:** $\pm 0.01\%$ of span max/ $^{\circ}\text{C}$
- f. **Load Effect:** $\pm 0.005\%$ zero to full load
- g. **Output Ripple:** 10 mv P/P maximum
- h. **Response Time:** 350 milliseconds (10 to 90% step response)
- i. **Bandwidth:** (-3 db): 1 Hz
- j. **Temperature Range:** -25 $^{\circ}$ to 185 $^{\circ}$ F (-31 $^{\circ}$ to 85 $^{\circ}$ C) operating
-40 $^{\circ}$ to 200 $^{\circ}$ F (-40 $^{\circ}$ to 93 $^{\circ}$ C) storage
- k. **Power Supply Effect:** $\pm 0.005\%$ over operating range
- l. **Isolation:** Input/output/case: 600 VAC, 1000 VDC

Note: All accuracies are given as a percentage of span

POWER

- a. 8 to 42 vdc—standard

MECHANICAL

- a. Electrical Classification: general purpose
- b. **Connection:** Screw, compression type, accepts up to 14 AWG
- c. Controls: One 16 position rotary switches for range control
Four multiturn potentiometers for ZERO, SPAN, SENSITIVITY, and HYSTERESIS control
- d. Mounting: Surface, Snap-Track, DIN or NEMA 4, 7 & 12
- e. Weight: Net Unit: 4 oz. (115 grams)
Shipping: Nominal 7 oz. (200 grams)

OPTIONS

Option Number	Description
H 15D through H 30	Mounting
LPI 40D	Loop-indicator

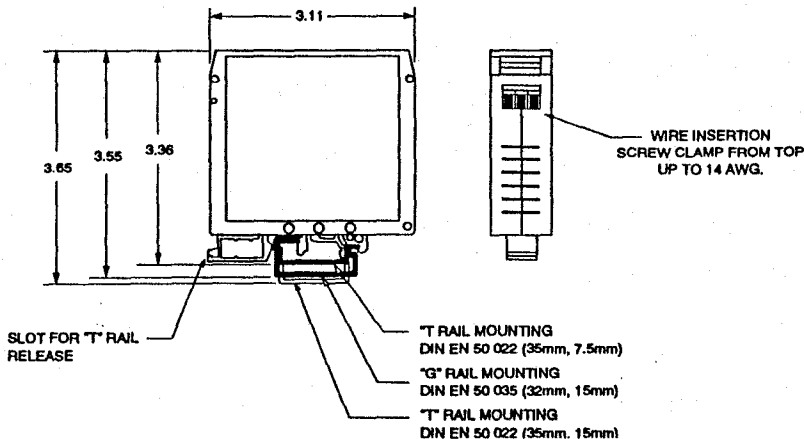
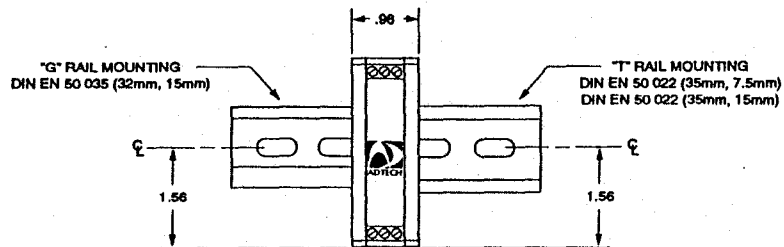

OPTIONAL MOUNTINGS – see separate drawings provided or request from the factory

- | | |
|-------------|--|
| Option H-15 | D Explosion Proof, Class 1, Group B, C & D |
| Option H-25 | Snap Track Mounting N/C (Specify) |
| Option H-26 | Surface Mounting N/C (Specify) |
| Option H-27 | NEMA 4 Enclosure |
| Option H-29 | T35 DIN T rail 2 Ft. Long |
| Option H-30 | T32 DIN G rail 2 Ft. Long |