



ADTECH
 Analog-Digital Technology, Inc.
 95 Mt. Read Blvd Suite 149
 Rochester, New York 14611 USA
 Phone 1.585.698.1845 Fax 1.585.697.0445

ALM 00

Analog Linearizer Module

Instruction Manual

1.0 INTRODUCTION

These instructions refer to the above model. Supplementary sheets are attached if the unit has special options or features. For detailed specifications, see page 4 or refer to the Data Bulletin. All ADTECH instruments are factory calibrated and supplied with a label detailing the calibration. Adjustments are normally not necessary. A simple check should be performed to verify calibration before installation to ensure that it matches the field requirement.

2.0 GENERAL DESCRIPTION

The ADTECH ALM 00 is a Non-Isolated Linearizer Module that accepts a standard process input signal of 1-5 vdc or 4-20 ma dc that is a function of a whole or fractional power and converts it into a linear output. The value of power is limited from 0.2 to 5. The standard model handles monotonic functions such as root extraction, power functions, or optionally logarithmic functions on a continuous calculation method (Option O 43). A breakpoint type non-monotonic function linearizer is optional (Option O 42).

Power Option P 1 Non-Isolated 24 vdc provides negative output signal and negative DC power common rail connection.

The output is a true current source and provides process signals such as 4-20 ma, 0-1 ma, 0-10 ma, 1-5 ma and 10-50 ma dc or alternatively, a voltage signal of 5 vdc full scale. Other current and voltage **Inputs/Outputs (I/O)** are available as specified on the Data Bulletin.

3.0 INSTALLATION

The instrument is supplied in a general purpose enclosure as standard. NEMA 4, 7 or 12 and plug in chassis enclosures are optionally available. Installation area/location must agree with the supplied instruments including operating temperature and ambient conditions.

Mounting

Refer to the appropriate outline drawing for mounting and clearance dimensions. The instrument is surface mounted with two #10-32 screws on 8.00 inch centers.

Electrical Connections

The wire used to connect the instrument to the control system I/O should be a twisted pair(s) and sized according to normal practice. Shielded cable is not normally necessary (if used, the shield must be grounded at the input negative of the ADTECH instrument and left floating at the sensor).

A 12 position barrier terminal block with #6-32 screws and 3/8" spacing is provided for I/O and power connection. A housing ground terminal marked G is also provided.

Controls

Multiturn INPUT ZERO, INPUT SPAN, OUTPUT ZERO, OUTPUT SPAN, LOG or EXPONENT and Optional 10

Segment Internal Controls one per segment are provided to calibrate the instrument. The multiturn controls are accessible through the instrument front panel and are clearly marked for ease of use.

4.0 MAINTENANCE

These instruments are electronic and require no maintenance except periodic cleaning and calibration verification. If the unit appears to be mis-operating it should be checked as installed per section 6.0 or removed for a bench check per sections 6.0-7.0. MOST problems are traced to field wiring and/or associated circuits. If the problem appears to be with the instrument, proceed to sections 6.0 and 7.0.

5.0 CONNECTIONS

Standard connections are shown below and on the instrument face plate, Data Bulletin or on attached supplementary sheets.

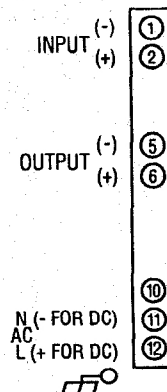

24VDC TWO-WIRE POWER
 OPTION "O 15"

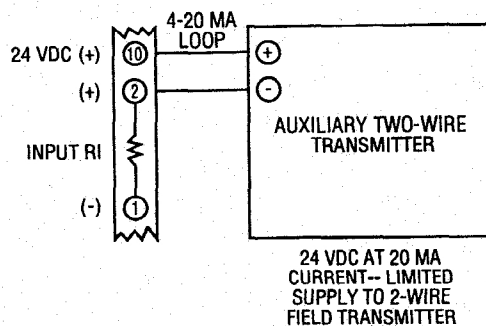

6.0 CALIBRATION (ROOT FUNCTION)

To perform a calibration check or re-calibration of the instrument follow this procedure.

- A. Carefully remove the instrument from the housing to gain access to the inside components observing normal safety and equipment precautions.
- B. Make sure the I/O wiring is properly connected and that the correct power source per the label is also connected. The instrument must be at normal power for a minimum of 2 minutes before proceeding to C.
- C. The input signal source(s) must be adjustable from 0 to 100% in steps of 10% or at least 25%. The source(s) should be either precalibrated or an accurate meter must be used to monitor the input(s).
- D. The output may be monitored either as a direct voltage for a voltage output signal or as a current that can be represented as a voltage across a resistor shunt.
- E. Set input source to 1% of input span and adjust the multiturn potentiometer marked IN-ZERO to provide 0.069 vdc from Terminal #4(+) to Terminal #5(-).
- F. Set input source to the maximum input value and adjust the multiturn potentiometer marked IN-SPAN to provide 0.069 vdc from Terminal #4(-) to Terminal #3(+).
- G. Temporarily connect a jumper from Terminal #1 to Terminal #7 and adjust the multiturn potentiometer marked OUT-ZERO to provide the minimum calibrated output (e.g.) 4.00 ma \pm 0.01 ma dc. Disconnect the temporary jumper.
- H. Set the input source to the maximum value of the input and adjust the multiturn potentiometer marked OUT-SPAN to provide the maximum calibrated output (e.g.) 20.00 \pm 0.01 ma dc.
- I. Set the input source to 50% of the input value and adjust the multiturn potentiometer marked EXP to provide the calculated desired value of the output per the equation

$$\text{Output (ma)} = 16 \left(\frac{I_{in} - 4}{16} \right)^n + 4.00$$

where I_{in} is the input signal 4-20 ma, $n = 0.2$ to 5.0
 (Note: This equation is given for 4-20 ma input and 4-20 ma output signal and must be suitably modified for other I/O signals.) The generalized form of the equation can be expressed as

$$\text{Output} = \text{Output Span} = \left(\frac{\text{Input} - \text{Input Live Zero}}{\text{Input Span}} \right)^n + \text{Output Live Zero.}$$

- J. The instrument should now be checked at 25% and 75% of the input span minimum.
- K. This completes the calibration.

7.0 FIELD TROUBLE SHOOTING GUIDE

This section offers a simple, first level trouble-shooting aid for an apparent instrument malfunction.

SYMPTOM CORRECTIVE ACTION

- | | |
|-----------|---|
| No output | <ol style="list-style-type: none"> 1. Check the input and output connections carefully. 2. Check that the power supply polarity is correct and that power is present on the instrument terminals. 3. Check that the input source(s) is correct and that it changes magnitude between zero and full scale values when so adjusted. 4. If the output is a current signal (4-20 ma, etc.), make sure the output loop is complete and that the correct meter range is selected. |
|-----------|---|

All external checks are complete. Problem seems to be internal.

The following information is provided for a qualified technician or serviceman as check points for use in internal troubleshooting.

<u>CHECKPOINT/ COMPONENT</u>	<u>VOLTAGE/ RANGE</u>
(across) C10	12 \pm 0.6 vdc
(across) C11	26 \pm 4 vdc
(across) VR1	6.9 \pm 0.35 vdc
(across) R97	0.2 - 1 vdc

6.1 CALIBRATION—10 SEGMENT (OPTION O 42)

Follow section 6.0 steps A through G and further calibrate per the table below.

STEP	INPUT (%)	Adjustment Potentiometer No.	Adjusted Output
H.	9.50	8	Desired Output
I.	19.50	9	Desired Output
J.	29.00	10	Desired Output
K.	38.50	11	Desired Output
L.	48.50	12	Desired Output
M.	58.50	13	Desired Output
N.	68.00	14	Desired Output
O.	78.50	15	Desired Output
P.	89.00	16	Desired Output
Q.	100.00	17	Desired Output

R. This completes the O 42 calibration.

Note: The desired output is determined from the curve to be linearized.

8.0 TABLES, PCB LAYOUT

INPUT TABLE

OUTPUT SIGNAL FULL SCALE	INPUT SHUNT RI
50 ma dc	100 ohm, 1/2 W
20 ma dc	250 ohm, 1/2 W
10 ma dc	499 ohm
1 ma dc	4.99K ohm
10 vdc	See Note 1
5 vdc	Out

NOTE 1: R81 = 150K, RA = 100K, R122 = out

OUTPUT TABLE

OUTPUT SIGNAL FULL SCALE	OUTPUT SHUNT RL	FEEDBACK RES RF
50 ma dc	NONE	20 ohm
20 ma dc	NONE	49.9 ohm
10 ma dc	NONE	100 ohm
1 ma dc	NONE	1K ohm
10 vdc	604 ohm, 1/4 W	49.9 ohm
5 vdc	250 ohm, 1/2 W	49.9 ohm

NOTE A: Components as shown may or may not be present on the p.c. board due to design updates or options.

ROOT/POWER TABLE

EXP. (n)	R104 OHM
0.2 - 0.35	301 K
0.35 - 0.7	499 K
0.7 - 1.3	1.00 M
1.3 - 2.3	2.00 M
2.3 - 4.0	3.01 M
4.0 - 5.0	4.99 M

ALM 00 RI = R122 RL = R102 RF = R96

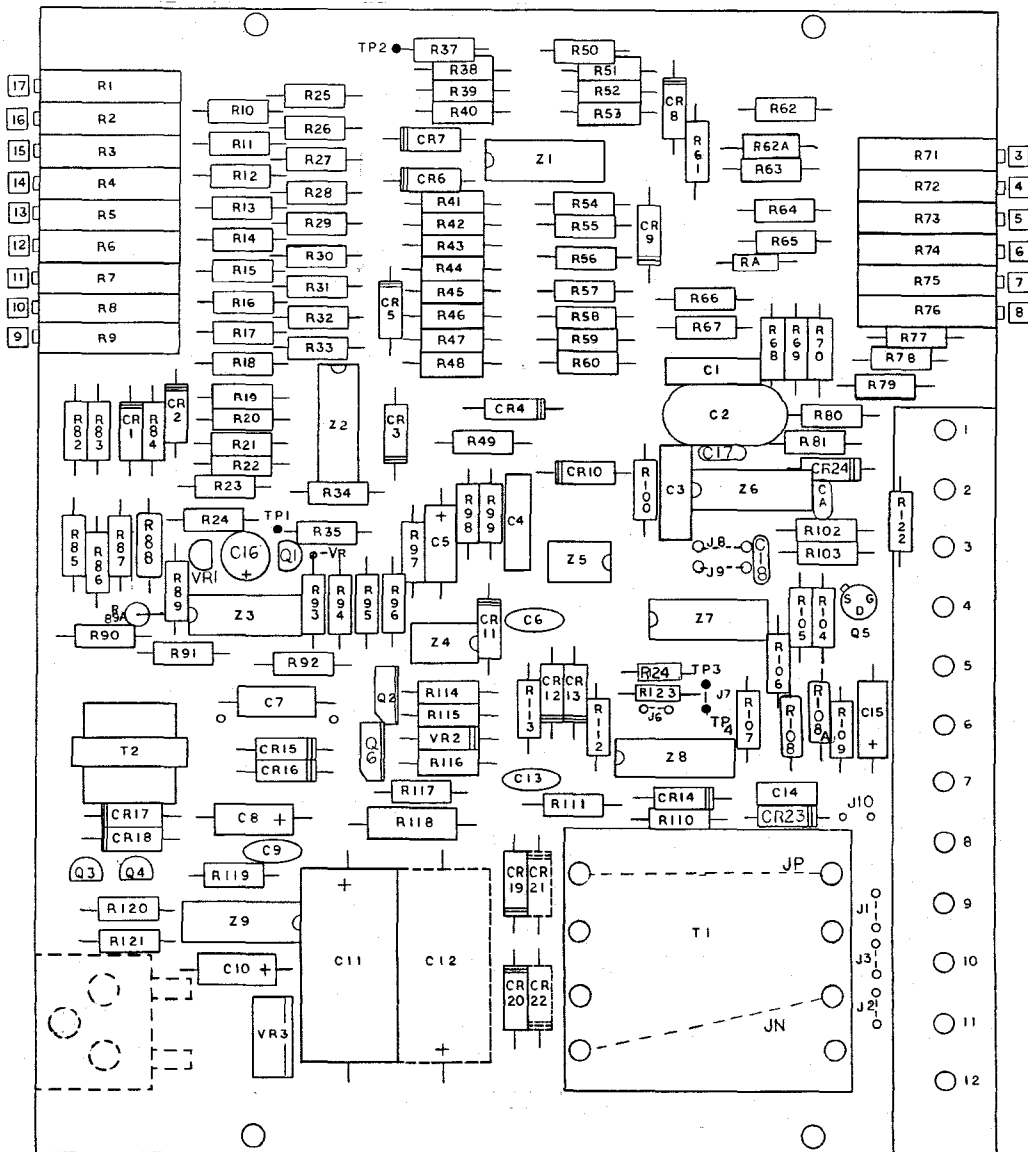

9.0 SPECIFICATIONS

INPUT/OUTPUT

INPUT SIGNALS

- 4-20 ma dc (Z in 250 ohms)
- 10-50 ma dc (Z in 100 ohms)
- 0-1 ma dc (Z in 5K ohms)
- 0-10 ma dc (Z in 500 ohms)
- 1-5 vdc (Z in 10 megohms)
- 0-5 vdc (Z in 10 megohms)
- 0-10 vdc (Z in 100K ohms)
- Other zero based current and voltages available
- Low impedance current inputs, 1/10 standard (Option I 18)

OUTPUT SIGNALS/OUTPUT DRIVE

	AC Power	DC Power
a. 4-20 ma dc	0-1000 ohms max.	0-900 ohms max.
b. 10-50 ma dc	0-400 ohms max.	0-350 ohms max.
c. 0-1 ma dc	0-20,000 ohms max.	0-18,000 ohms max.
d. 1-5 vdc	250 ohms Z out	250 ohms Z out
e. 0-10 vdc	500 ohms Z out	500 ohms Z out

Or zero based in the same ranges. Other voltage and currents optional.

PERFORMANCE

- Calibrated Accuracy:** $\pm 0.1\%$
 - Linearity:** $\pm 0.1\%$ maximum, $\pm 0.04\%$ typical
 - Repeatability:** $\pm 0.05\%$ maximum
 - Temperature Stability:** $\pm 0.01\%/^{\circ}\text{F}$ maximum, $\pm 0.004\%/^{\circ}\text{F}$ typical
 - Load Effect:** $\pm 0.01\%$ zero to full load
 - Output Ripple:** 10 mv P/P maximum
 - Response Time:** 150 milliseconds
 - Temperature Range:** 0° to 140°F (-18° to 60°C) operating
 -40° to 185°F (-40° to 85°C) storage
 - Power Supply Effect:** $\pm 0.05\%$ for a $\pm 10\%$ power variation
- * When supplied as a root or exponential function the response time is for 25% of range or greater.

Note: All accuracies are given as a percentage of span

6.2 CALIBRATION—LOG FUNCTION (OPTION O 43)

Follow steps A through F in section 6.0.

- Using the antilog/log tables (see Suppl. Option O 43) for input vs %output, pick a non-zero %input, %output pair for the desired decade setting. Apply the %input signal value to the unit. Adjust the potentiometer marked LOG until Z5 pin 5 equals $6.9 \times \% \text{output}$.
- Now from the log/antilog table used above apply the first %input, %output pair in the table. Adjust the potentiometer marked OUT-ZERO until the output at terminal 6(+), 5(-) represents the %output that corresponds to the %input applied.
- Now apply 100% input. Adjust the potentiometer marked OUT-SPAN until the output at (terminal 6(+), 5(-) represent 100% of the output.
- Now apply the same %input, %output pair as per step G and adjust the potentiometer marked LOG until the output represents the corresponding %output.
- Check other %inputs and repeat steps H through J until the desired accuracy is obtained.
- This completes the calibration.

POWER

- 115 vac: $\pm 10\%$, 50/60 Hz, 3 watts, 0.7 Pf (standard)
- 24 vdc: $\pm 10\%$ non-isolated, 3 watts (Option P1)
- 24 vdc: $\pm 10\%$ isolated, 3 watts (Option P2)
- 48 vdc: $\pm 10\%$ isolated, 3 watts (Option P3)
- 125 vdc: Nominal (105-140 vdc) isolated, 3 watts (Option P4)
- 230 vac: $\pm 10\%$, 50/60 Hz, 3 watts, 0.7 PF (Option P5)

10.0 OUTLINE & MOUNTING

