



ADTECH

95 Mt. Read Blvd # 149
Rochester, New York 14611 USA
Phone: 1.585.698.1845
Fax: 1.585.697.0445

www.adtech-inst.com

AMPLITUDE DISCRIMINATOR / HIGH-LOW SELECTOR MODULE MODEL NO. ADM 20

THE ADTECH MODEL ADM 20 AMPLITUDE DISCRIMINATOR / HIGH-LOW SELECTOR MODULE PROVIDES A SINGLE OUTPUT THAT REPRESENTS EITHER THE HIGHEST OR LOWEST OF THE 2, 3, OR 4 INPUT SIGNALS. IT UTILIZES PRECISION COMPARATOR NETWORKS TO PROVIDE BUMPLESS TRANSITION FROM SIGNAL TO SIGNAL. SELECTION OF HIGH OR LOW SELECT OPERATION IS ACHIEVED BY A SINGLE JUMPER SELECTION.

THE ADM 20 MAY BE ORDERED AS A THREE INPUT MEDIAN SIGNAL SELECTOR WITH OPTION I 27. THIS OPTION IS NORMALLY UTILIZED IN A CRITICAL PROCESS FOR INCREASED RELIABILITY. A TYPICAL APPLICATION IS ONE WHERE THREE PRIMARY TRANSMITTERS ARE USED TO MEASURE A SINGLE VARIABLE SUCH AS TEMPERATURE, PRESSURE LEVEL, ETC. THE MEDIAN SELECTOR INSURES THAT THE SELECTED SIGNAL IS REPRESENTATIVE OF THE PROCESS VARIABLE EVEN WHEN ONE OF THE THREE TRANSMITTERS FAILS UPSCALE OR DOWNSCALE FOR ANY REASON.

THE ADM 20 DELIVERS STANDARD PROCESS CURRENT OR VOLTAGE SIGNALS ON THE OUTPUT WITH A MAXIMUM OF 10 mV P/P OUTPUT RIPPLE.

RECALIBRATION TO OTHER DESIRED RANGES IS VERY CONVENIENT. THE USE OF TEMPERATURE-STABLE, LOW-NOISE COMPONENTS PROVIDES EXCELLENT STABILITY AND NOISE IMMUNITY. THE ADM 20 EMPLOYS THE LATEST DESIGN AND COMPONENTS FOR RELIABILITY, ACCURACY, AND SERVICEABILITY.

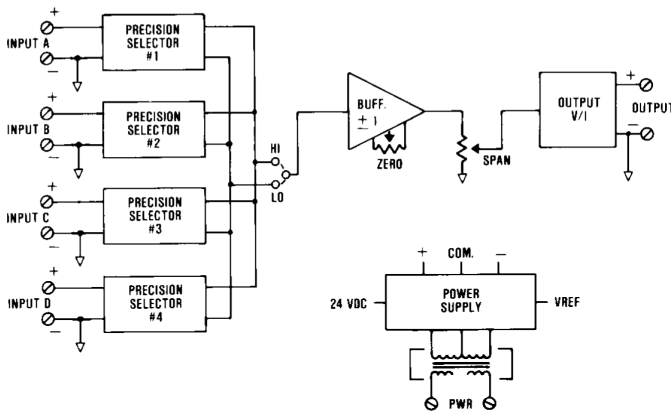

TYPICAL APPLICATIONS

- SOFT START OR SHUTDOWN
- HOT-SPOT TEMPERATURE MEASUREMENT
- LOWEST LEVEL MEASUREMENT
- HIGHEST LEVEL MEASUREMENT
- REDUNDANT LOSS OF SENSOR INTERFACE
- REDUNDANT SENSOR MAINTENANCE INDICATOR
- MEDIAN SELECTOR FOR CRITICAL PROCESSES

FEATURES

- DISCRIMINATOR / SELECTOR: HIGH OR LOW- STANDARD; MEDIAN OPTIONAL
- NUMBER OF INPUTS: 2, 3, OR 4 STANDARD
- DC CURRENT INPUTS: 4-20 MA, ETC.
- DC VOLTAGE INPUTS: 1-5 VDC, ETC.
- HIGH INPUT IMPEDANCE: 10 MEGOHMS MINIMUM
- DC PROCESS SIGNAL OUTPUTS: CURRENT AND VOLTAGE
- REPEATABILITY: $\pm 0.02\%$ OF SPAN
- HIGH ACCURACY: $\pm 0.1\%$ OF SPAN
- REVERSE CALIBRATION/ LINEAR INVERTER: OPTIONAL

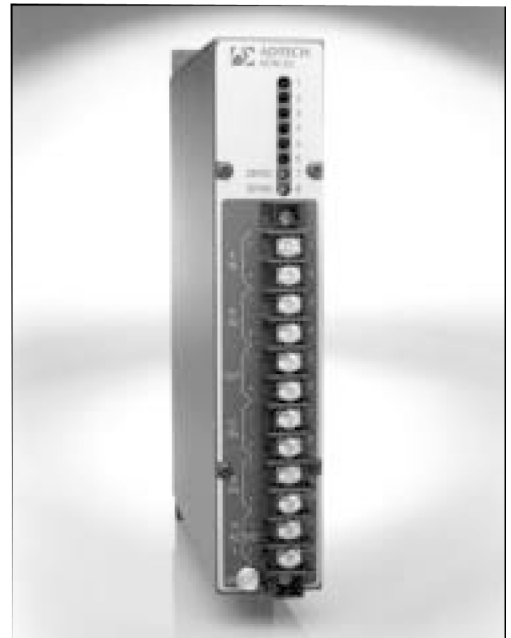

CONNECTIONS / DIMENSIONS

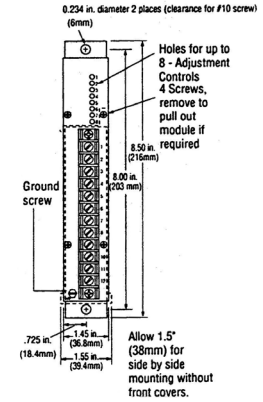
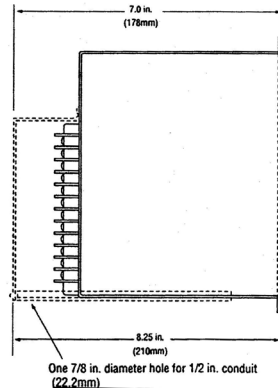
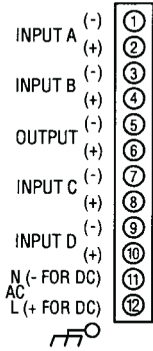

INPUT/OUTPUT

INPUT SIGNALS
(ANY MIX, 2 OR 4 INPUTS OF SAME RANGE)
4-20 mA DC (Z IN 250 OHMS)
10-50 mA DC (Z IN 100 OHMS)
0-1 mA DC (Z IN 5K OHMS)
0-10 mA DC (Z IN 500 OHMS)
1-5 VDC (Z IN 10 MEGOHMS)
0-5 VDC (Z IN 10 MEGOHMS)
0-10 VDC (Z IN 1 MEGOHM)
OTHER ZERO-BASED CURRENT AND VOLTAGES ARE AVAILABLE.

OUTPUT SIGNALS / OUTPUT DRIVE (RL)

SIGNAL	AC POWER (RL)	DC POWER (RL)
4-20 mA DC	0-1,000 OHMS MAX.	0-900 OHMS MAX.
10-50 mA DC	0-400 OHMS MAX.	0-350 OHMS MAX.
0-1 mA DC	0-20,000 OHMS MAX	0-18,000 OHMS MAX
1-5 VDC	100K OHMS MIN	100K OHMS MIN.
0-10 VDC	200K OHMS MIN	200K OHMS MIN.

PERFORMANCE

CALIBRATED ACCURACY: $\pm 0.1\%$
LINEARITY: $\pm 0.1\%$ MAX., $\pm 0.04\%$ TYPICAL
REPEATABILITY: $\pm 0.05\%$ MAXIMUM
TEMPERATURE STABILITY: $\pm 0.01\%/^{\circ}\text{F}$,
 $\pm 0.004\%/^{\circ}\text{F}$ TYPICAL
LOAD EFFECT: $\pm 0.01\%$ ZERO TO FULL LOAD
OUTPUT RIPPLE: 10 mV P/P MAXIMUM
RESPONSE TIME: 150 MILLISECONDS
NOTE: ALL ACCURACIES ARE GIVEN AS A PERCENTAGE OF SPAN

TEMPERATURE RANGE: 0° TO 140°F (-18° TO 60°C)
OPERATING: -40° TO 185°F (-40° TO 85°C) STORAGE
POWER SUPPLY EFFECT: $\pm 0.05\%$ FOR A
 $\pm 10\%$ POWER VARIATION

POWER

115 VAC: 50/60 HZ, 0.7 PF (STANDARD)
12 VDC: ISOLATED (OPTION P8)
24 VDC: NON-ISOLATED (OPTION P1)
24 VDC: ISOLATED (OPTION P2)

48 VDC: ISOLATED (OPTION P3)
125 VDC: ISOLATED (105-140 VDC) (OPTION P4)
230 VAC: 50/60 HZ, 0.7 PF (OPTION P5)

NOTE: ALL UNITS 3 WATTS MAXIMUM, AND A $\pm 10\%$ POWER VARIATION UNLESS NOTED.

MECHANICAL

ELECTRICAL CLASSIFICATION: GENERAL PURPOSE
CONNECTION: BARRIER TERMINAL STRIP (3/8" SPACING, NO. 6 SCREWS)
CONTROLS: MULTITURN ZERO AND SPAN CONTROLS
MOUNTING: SURFACE MOUNTING STANDARD. SEE HOUSINGS SECTION FOR OPTIONS.
WEIGHT: NET UNIT: 2.6 POUNDS (1.18 KILOGRAMS); SHIPPING: 3.0 POUNDS (1.6 KILOGRAMS)

OPTIONS

OPTION NUMBER	DESCRIPTION
I 27	MEDIAN SELECTOR
O 10	BIPOLAR CURRENT (LARGER THAN ± 1 MA)
O 11	BIPOLAR VOLTAGE TO ± 10 VDC: AT 1 MA, BIPOLAR CURRENT ± 1 MA
H 10	THIN-LINE CONDUIT MOUNTING PLATE AND TERMINAL COVER
H 13B, H 14B, H 15B	NEMA 4.7, AND 12 ENCLOSURES
H 16	PFA 12 HIGH-DENSITY, PLUG-IN ENCLOSURES

Ordering Information

- Model number
- Input signal--bias
- Output signal
- Prime power with option no.
- Input/output options
- Housing and miscellaneous options

Please refer to the Housing and/or Option Section for more specific and detailed information.