



ADTECH
 Analog-Digital Technology, Inc.
 830 Canning Parkway
 Victor, New York 14564-8940
 (585)869-6330 • FAX (585)869-1835

TCX-227 Smart Touch™ 2-Wire Isolated Temperature Transmitter Instruction Manual

1.0 INTRODUCTION

These instructions refer to the above model. Supplementary sheets are attached if the unit has special options or features. For detailed specifications, see page 4 or refer to the Data Bulletin. All ADTECH instruments are factory calibrated and supplied with a label detailing the calibration. Adjustments are normally not necessary. A simple check must be performed to verify calibration before installation to ensure that it matches the field requirement.

2.0 GENERAL DESCRIPTION

The TCX-227 transmitter accepts any of the 11 standard thermocouple input types and provides a linearized and isolated output representing temperature. Calibration is extremely easy with Adtech's **Smart Touch™** technology. Simply input your zero value, touch a button, input your full-scale value and touch another button, and the unit is calibrated.

The isolated output resolution is 12 bits and provides standard 2-wire current output signal. Isolation is 600 volts ac or 1000 volts dc from the input to the output / power supply. Power requirement is 12 to 42 Vdc.

The primary features are:

- Wide range - covers the full usable range of 11 NIST standard thermocouple types.
- High accuracy, input resolution to $0.3\mu\text{v}$.
- Update rate of 20Hz, -3db response of 5.24 Hz (0.067 msec) standard.
- RFI resistant.
- No interaction of ZERO and SPAN controls.
- Adtech Smart Touch™ calibration.
- Small size - DIN mounting package (1"w x 3.1"h x 3.6"d).
- Options for NEMA 4 and NEMA 7 housings, SNAP TRAK and surface mounting.

3.0 INSTALLATION

Electrical Connections

The wire used to connect the instrument to the control system I/O should be a twisted pair(s) and sized according to normal practice. Shielded cable is not normally necessary (if used, the shield must be grounded at the input negative of the ADTECH instrument and left floating at the sensor).

Six position compression terminal blocks are provided for I/O and power connection. A housing ground terminal is not required due to non-metallic housing.

Controls

Instrument controls consist of the following:

- 8 position switch for input configuration and calibration options.
- Input ZERO and SPAN push buttons (Adtech **Smart Touch™**)
- Output ZERO and SPAN pots.

4.0 MAINTENANCE

These instruments are electronic and require no maintenance except periodic cleaning and calibration verification. If the unit appears to be mis-operating it should be checked per sections 6.0 and 7.0. MOST problems are traced to field wiring and / or associated circuits. If the problem appears to be with the instrument, proceed to sections 6.0 and 7.0.

5.0 CONNECTIONS

Standard connections are shown below and on the instrument face plate, Data Bulletin or on attached supplementary sheets.

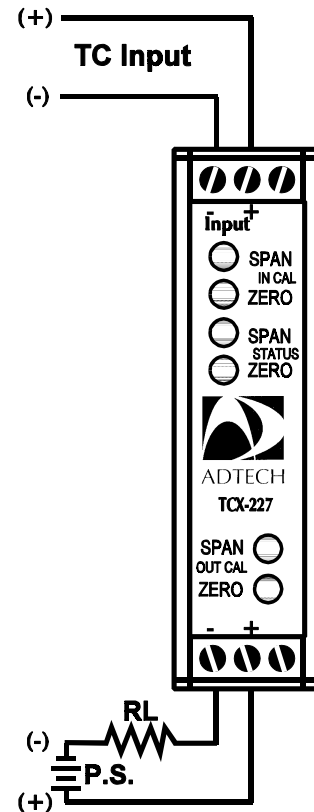

6.0 CONFIGURATION

All ADTECH units are factory calibrated per sales order instructions. Usually, a complete recalibration is not required unless you want to change input type, output type, or the range of the unit. A calibration sticker located on the unit identifies the model, calibration and options present.

NOTE: For recalibration to the existing range proceed to section 6.1; for new input type or range proceed as follows.

- A. Remove power from the unit. Remove the right cover to expose the 8 position switch and Jumper J1 on the input PCB (just above the potentiometers).
- B. Set switch 3 position 1 for upscale or downscale burnout. Set switch 3 position 2 to Linearized or non-linearized per table 1, section 8.0. Re-apply power to the unit.
- C. Set switch 3 position 3 to the on position and adjust the output ZERO potentiometer for the proper output.
- D. Set switch 3 position 3 to off and position 4 to on. Adjust the output SPAN potentiometer for full scale output. Repeat steps D and E until you reach the desired accuracy. (Note: you can check the midscale value by depressing switch 3 positions 3 and 4 simultaneously.)
- E. Return switch 3 positions 3 and 4 to the off position, and proceed with section 6.1 below to finish the calibration.

6.1 CALIBRATION

- A. Apply the zero input value at the input terminals of the unit. Depress and hold the ZERO input calibration push button switch until the ZERO status led flashes. You have just set the input zero, and the output should be at your zero value after a short time delay.
- B. Apply the full scale input value at the input terminals. Depress and hold the SPAN input calibration push button switch until the SPAN status led flashes. You have just set the full scale value and the output should be at full scale after a short delay.
- C. Calibration is complete. Check the calibration with various input values and verify the output values.

7.0 FIELD TROUBLE SHOOTING GUIDE

This section offers a simple, first level trouble-shooting aid for an apparent instrument malfunction.

SYMPTOM

CORRECTIVE ACTION

No Output

1. Check the input and output connections carefully.
2. Check that the power supply polarity is correct and that the output loop power is present on the indicated terminals.
3. Check that the input source(s) is correct and that it changes magnitude between zero and full scale values when so adjusted.
4. Make sure the output loop is complete and that the correct meter range is selected.

All external checks are complete.
Problem seems to be internal.

The instrument is made of small components. Troubleshooting beyond the above may be difficult with out special equipment. We do not recommend attempting repair of the unit in the field. ADTECH offers a very responsive repair policy. Contact the ADTECH factory for information on repair and return at 585-869-6330 or 585-869-1835(FAX).

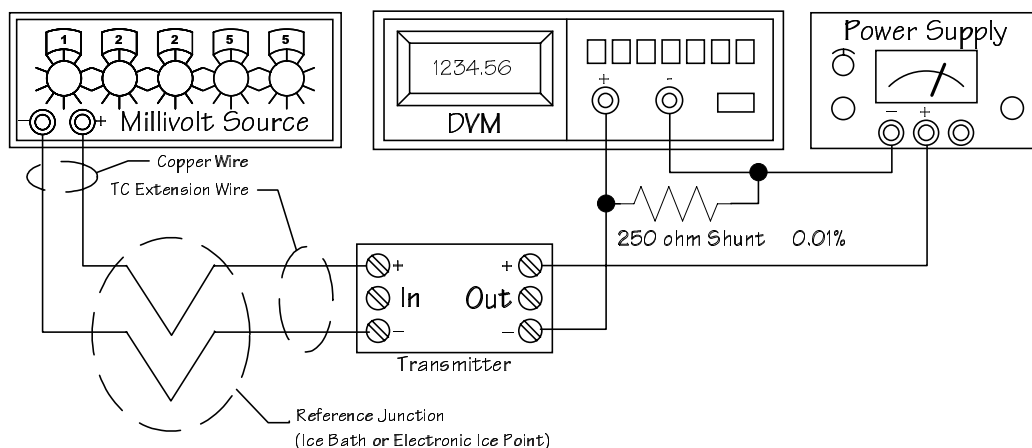

Typical Test Connection

8.0 TABLES

Configuration Switch SW3

Switch Position	Function	
1	Off	Downscale burnout
	On	Upscale burnout
2	Off	No Linearization
	On	Linearized
3	Off	Normal Operation
	On	Output the zero Value
4	Off	Normal Operation
	On	Output the span Value
5,6,7,8	See Table 2	

Table 1

Configuration Switch SW3 - TC Type

TC Type	5	6	7	8
B	Off	Off	Off	Off
C	On	Off	Off	Off
D	Off	On	Off	Off
E	On	On	Off	Off
G	Off	Off	On	Off
J	On	Off	On	Off
K	Off	On	On	Off
N	On	On	On	Off
R	Off	Off	Off	On
S	On	Off	Off	On
T	Off	On	Off	On

Table 2

T/C Range and Error

T/C Type	Range (°C)	Min A/D Resolution (°C)	Linearization Conformance Error (°C)
J	-210 to 1200	0.12	0.1
K	-200 to 1372	0.16	0.1
T	-200 to 400	0.08	0.1
E	-200 to 1000	0.10	0.1
N	-200 to 1300	0.24	0.1
B	250 to 1820	0.24	0.11
R	-50 to 1768	0.32	0.12
S	-50 to 1768	0.30	0.10
G	0 to 2315	0.8	0.13
C	0 to 2315	0.25	0.10
D	0 to 2320	0.25	0.12

Table 3

Notes:

1. Cold junction sensor accuracy is 0.5 °C over the operating temperature range.
2. Minimum A/D resolution is the equivalent temperature per bit at the least sensitive portion of the thermocouple range. Typical values are 0.04 °C in the normal operating range of the thermocouples.
3. Linearization conformance is the error from the NIST tables at a given μV equivalent.

8.1 PCB LAYOUT

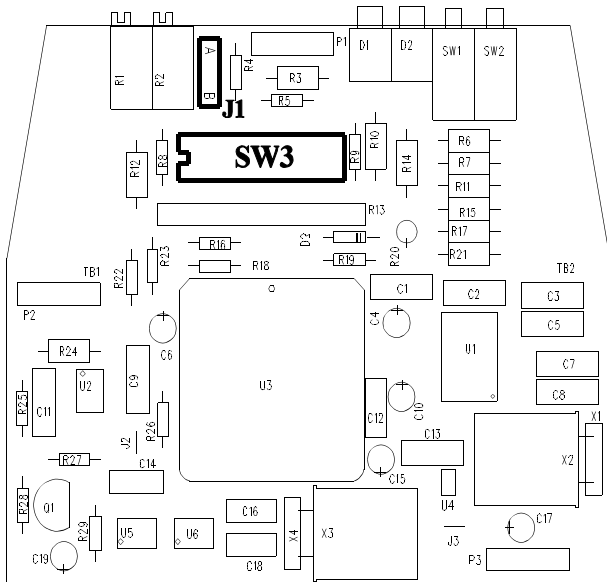

Input PCB

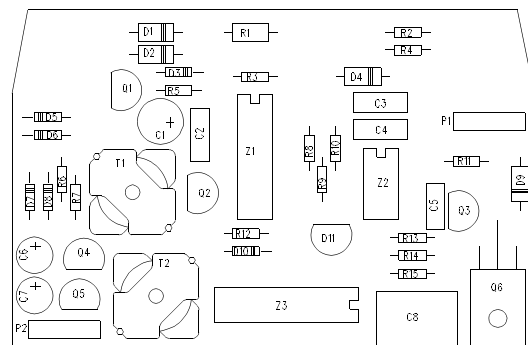

Output PCB

9.0 SPECIFICATIONS

INPUT/OUTPUT

INPUT SIGNAL

- Standard NIST Thermocouple (see Table 2 and 3) (Z in greater than 22 megohm).
- Conversion to $0.3\mu\text{V}$ input resolution linearized to 0.1°C conformance - (rms measured noise at 20 Hz conversion rate is $5\mu\text{V}$ maximum). Conversion is filtered to 5.24 Hz bandwidth.

OUTPUT SIGNALS

4-20 mA DC 2-Wire Output

$$R(\text{ohm}) = \frac{(V_{\text{supply}} - 12)1000}{I_{\text{out max. mA}}}$$

OUTPUT LOOP DRIVE CAPABILITY

I out	4-20 mA (22 mA maximum)			
V supply	15	24	36	42
R (ohm)	150	600	1200	1500

PERFORMANCE

- Calibrated Accuracy:** $\pm 0.1\%$ of mv input
- Independent Linearity:** $\pm 0.05\%$ maximum; $\pm 0.02\%$ typical
- Repeatability:** $\pm 0.01\%$ maximum; $\pm 0.004\%$ typical
- Zero TC:** $\pm 0.15\mu\text{V}/^\circ\text{C}$
- Span TC:** ± 30 ppm of span $\text{max}/^\circ\text{C}$
- Load Effect:** $\pm 0.005\%$ zero to full load
- Output Ripple:** 10 mV (p-p) maximum
- Response Time:** 67 milliseconds (10 to 90% step response)
- Bandwidth (-3 db):** 5.24 Hz
- Temperature Range:** -25° to 185°F (-31° to 85°C) operating; -40° to 200°F (-40° to 93°C) storage

- Power Supply Effect:** $\pm 0.005\%$ over operating range
 - Isolation:** Input/output/case: 600 VAC, 1000 VDC
 - Cold Junction Sensor Error:** 0.5°C max (-31° to 85°C)
 - Burnout current:** $0.1\mu\text{A}$ - nominal
- Note: All accuracies are given as a percentage of span

POWER

- 12 to 42 VDC - standard two wire connection

MECHANICAL

- Electrical Classification:** general purpose
- Connection:** Screw, compression type, accepts up to 14 AWG
- Controls:** 8 position switch, input ZERO and SPAN push button switch and status led's, output SPAN and ZERO pots
- Mounting:** DIN Surface, Snap-Track, or NEMA 4,7
- Weight: Net Unit:** 4 oz (115 grams)
Shipping: 7 oz (200 grams)

OPTIONS

Option Number	Description
H 15D	Explosion Proof: Class 1, Group B, C & D
H 23	Two (2) inch pipe mounting plate and clamps
H 25	Snap track mounting (specify)
H26	Surface mounting (specify)
H 27	NEMA 4 enclosure (up to 3 units)
H 29	T 35 DIN "T" rail two (2) feet long
H 30	T 32 DIN "G" rail two (2) feet long

10.0 OUTLINE MOUNTING

