



ADTECH
Analog-Digital Technology, Inc.

The Adtech Model SCX 202 Isolated Two Wire Signal Converter provides a user configurable solution for ground loops and problems encountered in connecting together recorders, process control systems, computers, DCS and PLC systems.

The SCX 202 breaks the galvanic path with 600 VAC/1,000 VDC input to output isolation between the transmitted signal and the output receiving device, insuring reliable and accurate signal transfer.

It is highly useful for applications that require signal isolation to eliminate ground loops, instrumentation level shifts, or the conditioning of a process signal riding over high common mode AC or DC voltages. Another common application is to provide additional amplification or drive to a process signal loop.

It delivers a standard process current 4-20 mA DC signal on the output with a maximum of 10 mV P/P output ripple. This provides convenient interfacing of process signals to a computer system or other process instrumentation for improved resolution.

Zero and span controls are provided by two separate infinite resolution potentiometers. Recalibration to other ranges in the field is easy and convenient.

Din mounting is supplied as standard. Surface mount (option H 26) and snap track (option H 25) are available at no extra cost, specify.

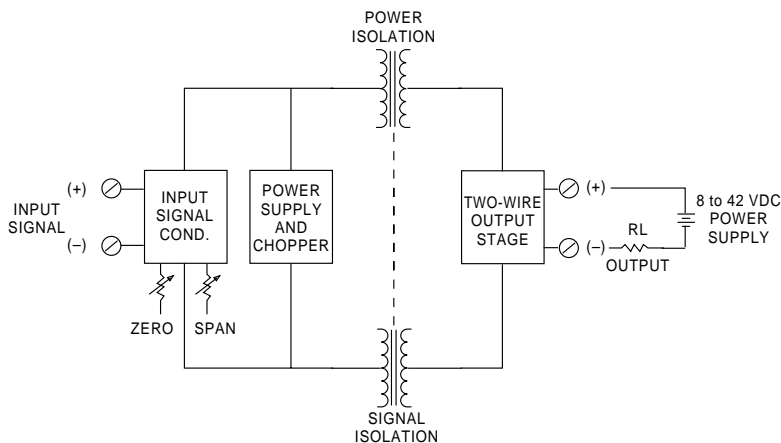

Features

- **DC Current Inputs:** 1 mA to 20 mA DC: (e.g. 4-20 mA DC)
- **DC Voltage Inputs:** 100 mV to 200 VDC: (e.g. 1-5 VDC)
- **Unipolar or Bipolar Inputs:** Current or voltage
- **Temperature Coefficients:**
Zero = $\pm 0.007\%/^{\circ}\text{C}$ of span-max.
Span = $\pm 0.0080\%/^{\circ}\text{C}$ of span-max.
- **Repeatability:** $\pm 0.002\%$ typical
- **Power:** 8 to 42 VDC

Isolated Two Wire Signal Converter

Model No. SCX 202

Typical Applications

- **Interface unequal or non-compatible plant ground systems**
- **Interface non-compatible instruments**
- **DCS-PLC-PC Interface**
- **Isolate interference on signal lines**
- **Impedance conversion**



Connections/Dimensions

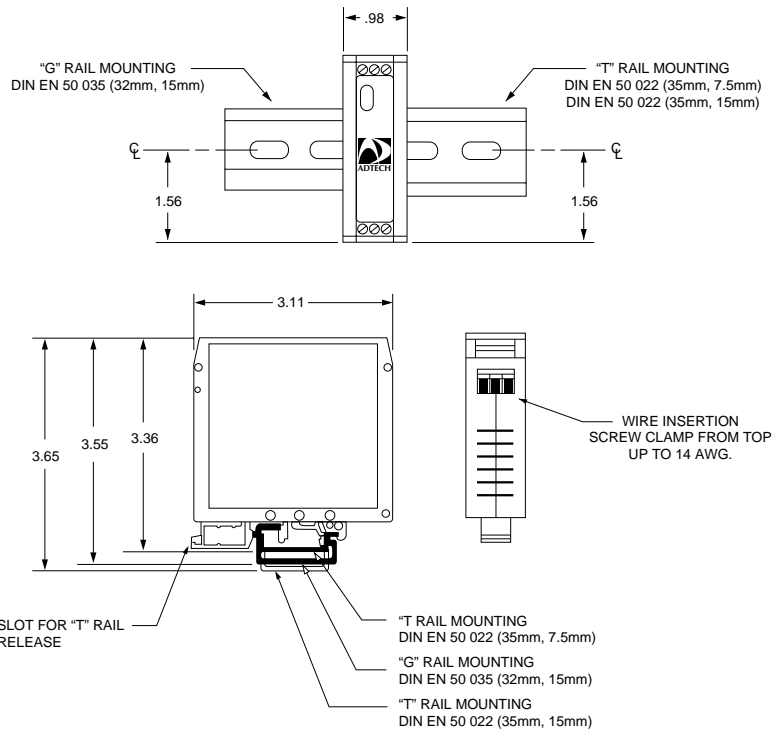
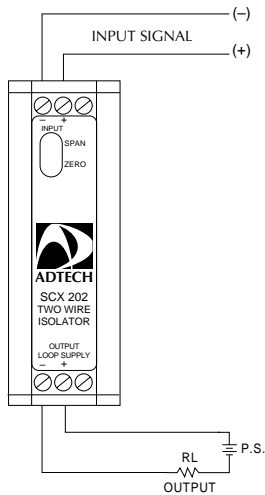

Input/Output

Input Signals:
 4-20 mA DC (Z in 10 ohms)
 0-20 or ± 20 mA DC (Z in 10 ohms)
 0-10 or ± 10 mA DC (Z in 20 ohms)
 0-1 or ± 1 mA DC (Z in 200 ohms)
 1-5 VDC (Z in 1 megohm)
 0-5 or ± 5 VDC (Z in 1 megohm)
 0-10 or ± 10 VDC (Z in 1 megohm)
 Any unipolar or bipolar voltage from
 100 mV to 200 VDC (Option 1 14)

Zero Suppression: 10%
Span Adjustment: 10%

Output Signal:
 4-20 mA DC
Output Loop Drive Capability
 $R \text{ (ohm)} = \frac{(V \text{ supply} - V \text{ minimum}) 1000}{I \text{ out max. ma}}$
 $V \text{ minimum} = 8.0 \text{ vdc}$

Iout	4-20 mA			
V supply	12	24	36	42
R(ohms)	200	800	1400	1700

Performance

Calibrated Accuracy: $\pm 0.1\%$
Independent Linearity: $\pm 0.025\%$ max.,
 $\pm 0.01\%$ typ.
Repeatability: $\pm 0.005\%$ max., $\pm 0.002\%$ typ.
Zero TC: $\pm 0.007\%$ of span max./ $^{\circ}\text{C}$
Span TC: $\pm 0.008\%$ of span max./ $^{\circ}\text{C}$
Load Effect: $\pm 0.005\%$ zero to full load
Output Ripple: 10 mV P/P maximum

Temperature Range:
 -25 $^{\circ}$ to 185 $^{\circ}\text{F}$ (-31 $^{\circ}\text{C}$ to 85 $^{\circ}\text{C}$) operating;
 -40 $^{\circ}$ to 200 $^{\circ}\text{F}$ (-40 $^{\circ}\text{C}$ to 93 $^{\circ}\text{C}$) storage
Power Supply Effect: $\pm 0.005\%$ of span, max.
Isolation: Input/output/case: 1000 VDC or 600
 VAC
Response Time: 110 milliseconds
 (10 to 90% step response)
Bandwidth: (-3db): 3.2 Hz

Note: All accuracies are given as a % of span.

Power Mechanical

8 to 42 VDC standard

Electrical Classification: General purpose
Connection: Screw compression type
 accepts up to 14 AWG

Mounting: DIN - standard (See other options below)
Controls: Multiturn potentiometers for Zero and Span,
 and jumpers for ranges
Weight: Net unit: 4.0 oz. (115 grams)
 Shipping: 7.0 oz. (200 grams)

Options

Option Number	Description
I 14	Voltage Inputs to 200 VDC, 1 megohm min. Impedance; Current Inputs of 100 mA max.
H 15D	Explosion Proof: Class 1, Group B, C & D
H 23	Two (2) inch pipe mounting plate & clamps
H 25	Snap track mounting (specify)
H 26	Surface mounting (specify)
H 27	NEMA 4 enclosure (up to 3 units)
H 29	T 35 DIN "T" rail two feet long
H 30	T 32 DIN "G" rail two feet long

Ordering Information

- Model number
- Input signal
- Prime power
- Input options
- Output signal
- Housing and miscellaneous options

Please refer to the Housing and/or Option Section for more specific and detailed information.

Represented by:



Analog-Digital Technology, Inc.
 830 Canning Parkway
 Victor, New York 14564-8940
 Phone: (585) 869-6330
 Fax: (585) 869-1835
 E Mail: adtech@adtech-inst.com
 Web site: http://www.adtech-inst.com