



ADTECH
Analog-Digital Technology, Inc.

The Adtech Model SCT 302 DC powered Isolated Signal Converter provides a user configurable solution for ground loops and problems encountered in connecting together recorders, process control systems, computers, DCS and PLC systems.

The SCT 302 breaks the galvanic path with 600 VAC/1,000 VDC input to output isolation between the transmitted signal and the output receiving device, insuring reliable and accurate signal transfer.

It is highly useful for applications that require signal isolation to eliminate ground loops, instrumentation level shifts, or the conditioning of a process signal riding over high common mode AC or DC voltages. Another common application is to provide additional amplification or drive to a process signal loop.

Output signal negative and power negative are common.

It delivers standard process current or voltage signals on the output with a maximum of 10 mV P/P output ripple. This provides convenient interfacing of process signals to a computer system or other process instrumentation for improved resolution.

Zero and span controls are provided by two separate infinite resolution potentiometers. Recalibration to other ranges in the field is easy and convenient.

Din mounting is supplied as standard. Surface mount (option H 26) and snap track (option H 25) are available at no extra cost, specify.

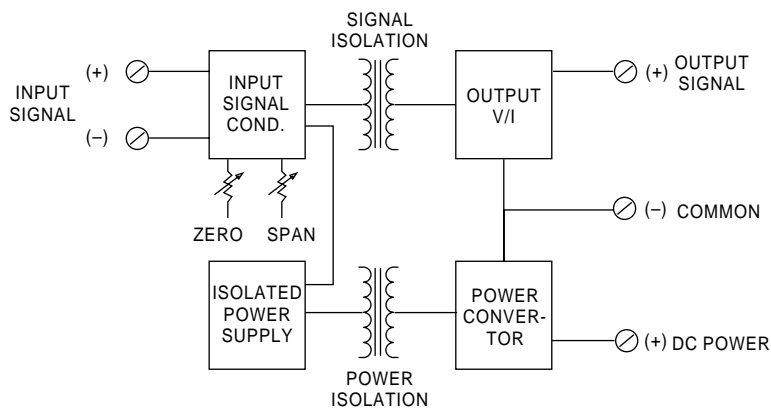

Features

- **DC Current Inputs:** 1 mA to 20 mA DC: (e.g. 4-20 mA DC)
- **DC Voltage Inputs:** 100 mV to 200 VDC: (e.g. 1-5 VDC)
- **Unipolar or Bipolar Inputs:** Current or voltage
- **DC Process Signal Outputs:** Current or voltage
- **Temperature Coefficients:**
Zero = $\pm 0.007\%/^{\circ}\text{C}$ of span-max.
Span = $\pm 0.008\%/^{\circ}\text{C}$ of span-max.
- **Repeatability:** $\pm 0.002\%$ typical
- **Power:** 15-42 VDC, 28 mA typical

Isolated Signal Converter DC Powered

Model No. SCT 302

Typical Applications

- **Interface unequal or noncompatible plant ground systems**
- **Interface non-compatible instruments**
- **DCS-PLC-PC Interface**
- **11 solate interference on signal lines**
- **Impedance conversion**



Connections/Dimensions

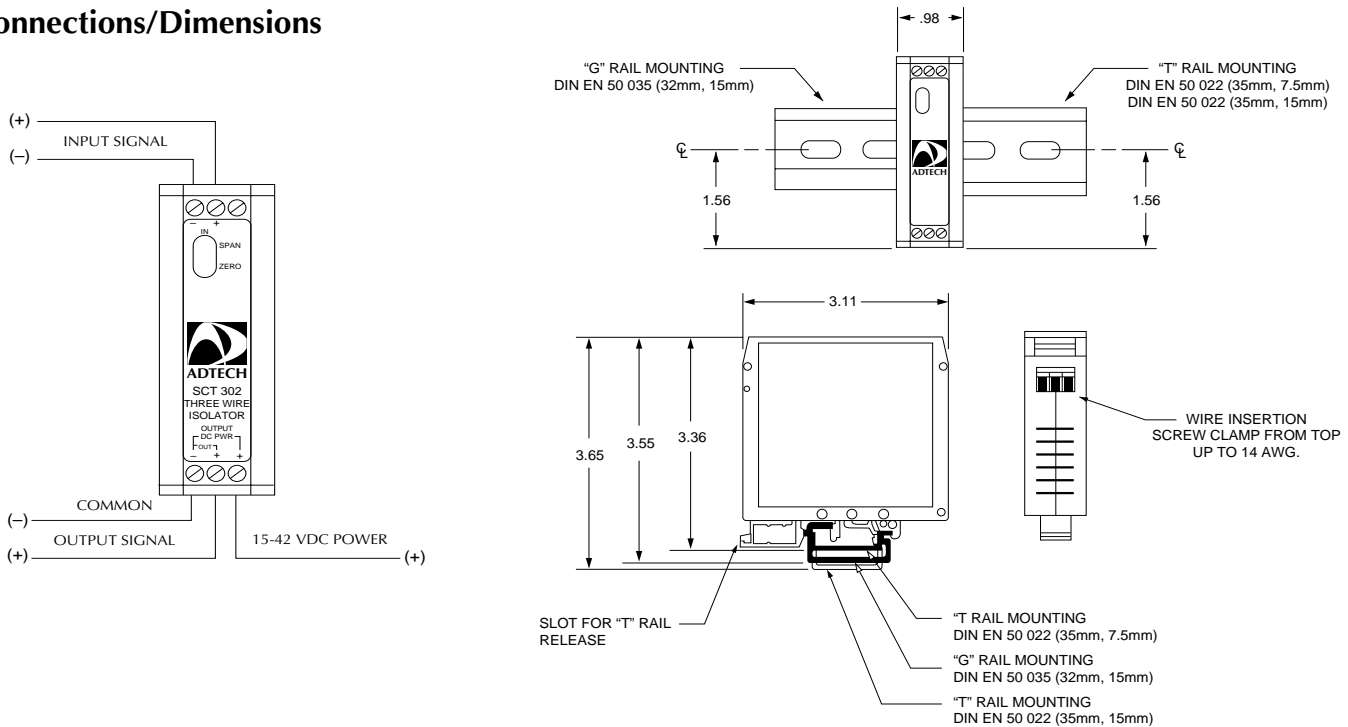

Input/Output

Input Signals: Pin Jumper Configurable
 4-20 mA DC (Z in 10 ohms)
 0-20 or ± 20 mA DC (Z in 10 ohms)
 0-10 or ± 10 mA DC (Z in 20 ohms)
 0-1 or ± 1 mA DC (Z in 200 ohms)
 1-5 VDC (Z in 1 megohms)
 0-5 ± 5 VDC (Z in 1 megohm)
 Any unipolar or bipolar voltage
 from 100 mV to 200 VDC (Option 114)

Zero Suppression: $\pm 10\%$
Span Adjustment: $\pm 10\%$

Output Signals:

4-20 mA DC; 0-20 mA DC; 0-1 mA DC;
 0-1 mA DC; 1-5 VDC; 0-5 VDC; 0-10 VDC

Output Loop Drive Capability:

$R(\text{ohm}) = \frac{(V \text{ supply} - 5) I_{\text{out max. mA}}}{V \text{ Supply: 15 to 42 VDC}}$

I _{out}	4-20 mA or 0-20 mA			
V supply	15	24	36	42
R(ohms)	500	950	1550	1850

Performance

Calibrated Accuracy: $\pm 0.1\%$
Independent Linearity: $\pm 0.025\%$ max.
 $\pm 0.01\%$ typical
Repeatability: $\pm 0.005\%$ max., $\pm 0.002\%$ typ.
Zero TC: $\pm 0.007\%$ of span max./ $^{\circ}\text{C}$
Span TC: $\pm 0.008\%$ of span max./ $^{\circ}\text{C}$
Load Effect: $+0.005\%$ zero to full load
Output Ripple: 10 mV P/P max.

Response Time: 110 ms (10 to 90% step response)

Bandwidth: (-3db): 3.2 Hz

Temperature Range:

-25 $^{\circ}$ to 185 $^{\circ}$ F (-31 $^{\circ}$ to 85 $^{\circ}$ C) operating;

-40 $^{\circ}$ to 200 $^{\circ}$ F (40 $^{\circ}$ to 93 $^{\circ}$ C) storage

Power Supply Effect: $\pm 0.005\%$ of span, max.

Isolation: Input/output/case: 1,000 VDC, or 600 VAC

Note: All accuracies are given as a percentage of span.

Power

15-42 VDC, 28 mA typical, 33 mA maximum

Mechanical

Electrical Classification: General purpose

Mounting: DIN: Optional surface, snap track or Nema 4 & 7.

Connection: Screw compression type
 accepts up to 14 AWG

Weight: Net unit: 4.0 oz. (115 grams)
 Shipping: 7.0 oz. (200 grams)

Controls: Multiturn zero and span controls
 and jumpers for ranges

Options

Option Number	Description
I 14	Voltage Inputs to 200 VDC, 1 megohm min. impedance; Current Inputs of 100 mA max.
H 15D	Explosion Proof: Class 1, Group 13,C & D
H 25	Snap-Track Mount (Specify)
H 26	Surface Mounting (Specify)
H 27	NEMA 4 Enclosure
H 29	T 35 DIN "T" rail two feet long
H 30	T 32 DIN "G" rail two feet long

Ordering Information

- Model number
- Input signal
- Output signal
- Prime power
- Input/output options
- Housing and miscellaneous options

Please refer to the Housing and/or Option Section for more specific and detailed information.

Represented by:



Analog-Digital Technology, Inc.
 830 Canning Parkway
 Victor, New York 14564-8940

Phone: (585) 869-6330

Fax: (585) 869-1835

E Mail: adtech@adtech-inst.com

Web site: http://www.adtech-inst.com