



ADTECH
Analog-Digital Technology, Inc.

3750 Monroe Avenue
Pittsford, New York 14534-1302
(716) 383-8280 • FAX (716) 383-8386

RBX 172 Two-Wire Isolated Resistance Bulb Transmitter
RBX 174 Two-Wire Non-Isolated Resistance Bulb Transmitter
Instruction Manual

1.0 INTRODUCTION

These instructions refer to the above models. Supplementary sheets are attached if the unit has special options or features. For detailed specifications, see page 4 or refer to the Data Bulletin. All ADTECH instruments are factory calibrated and supplied with a label detailing the calibration. Adjustments are normally not necessary. A simple check must be performed to verify calibration before installation to ensure that it matches the field requirement.

2.0 GENERAL DESCRIPTION

The ADTECH Model RBX 172 and RBX 174 Two-Wire RTD Transmitters provide high accuracy conversion of resistance bulb sensor input signals to a standard 4-20 ma dc process signal.

The RBX 172 provides 350 volts ac or 600 volts dc isolation from the input to output/power supply, whereas the RBX 174 is non- isolated.

The primary features of the RBX 174 and RBX 172 are:

- Wide range – Covers the entire range of 100 ohm Platinum or 120 ohm Nickel RTD's – switch selectable.
- Provide linearization of Platinum and Nickel Rtd's.
- Zero elevation or suppression upto 100% of the major range with a 16 position switch.
- Field adjustable via front accessible switches and potentiometers.
- High accuracy, repeatability, and ambient effect stability.
- RFI Protection: Standard.
- NO INTERACTION of ZERO and SPAN.
- Small size – universal mounting package provides integral RFI protection and an environmental seal.
- Options for NEMA housings, SNAP TRAK and DIN rail mounting (DIN 46 277 standard).

3.0 INSTALLATION

The instrument is supplied in a sturdy die cast aluminum housing with an epoxy paint finish. The housing is gasketed providing an environmental seal for the internal electronics and controls. NEMA 4, 7 and 12, Snap Track and DIN rail (TS32 and TS35) are optionally available. Installation area and location must agree with the supplied instruments including operating temperature and ambient conditions.

Mounting

Refer to page 3 for outline and mounting dimensions. The standard instrument is surface mounted with integral #6-32 S.S. thumb screws.

Electrical Connections

The wire used to connect the instrument to the control system Input / Output should be twisted pair(s) and sized

according to normal practice. Shielded cable is not normally necessary (if used, the shield must be grounded at terminal 1 of the ADTECH instrument and left floating at the sensor). Two barrier terminal blocks with #6-32 screws and 0.325" spacing are provided for I / O connections.

Controls

Instrument controls consist of the following:

- Two 16 position range switches for **COARSE ZERO** and SPAN control.
- One 8 position dip switch for selection of major range and RTD type.
- Two multiturn potentiometers; **FINE ZERO** and SPAN controls.

All controls are accessible through the front of the instrument. An integral gasketed cover provides an environmental seal for the controls and internal electronics when the controls are not in use.

4.0 MAINTENANCE

These instruments are electronic and require no maintenance except periodic cleaning and calibration.

If the unit appears to be mis-operating, field wiring and/or associated circuits should be checked. MOST problems are traced to these areas.

If the problem appears to be the instrument, it may be checked as installed or removed for a bench check as detailed in sections 6.0 and 7.0.

5.0 CONNECTIONS

Standard connections are shown below and on the instrument face plate, Data Bulletin or on attached supplementary sheets.

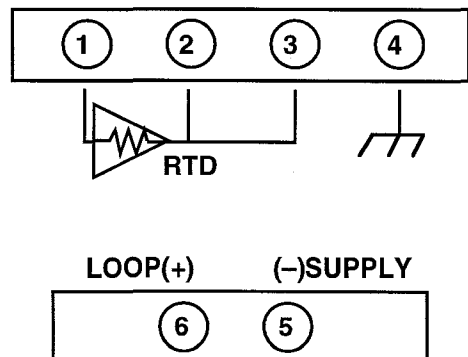

NOTE 1: See 2 Wire and 4 Wire RTD connection on page 2.

NOTE 2: Intrinsically safe when connected per Installation DWG 270-A-000003.

6.0 CALIBRATION

All ADTECH instruments are calibrated per your instructions at the factory. A calibration sticker located on the unit identifies the model, calibration, and options present.

To perform a calibration check or re-calibration of the instrument, please follow this procedure.

- A. Make sure the unit I / O wiring is properly connected and that the correct power source per the label is also connected. The instrument must be at normal power for a minimum of 2 minutes before proceeding to B.
- B. The input signal source must be adjustable from 0 to 100% in steps of 10% or at least 25%. The source should be either precalibrated or an accurate meter must be used to monitor the input.
- C. The output may be monitored as a current that can be represented as a voltage across a resistor shunt.
- D. Set switch S₁ positions 7 and 8 to the desired **MAJOR** range setting (see section 8.0). Set the desired RTD type (switch S₁ positions 1 and 2 for Platinum, positions 3 and 4 for Nickel). If the measured temperature range starts below 0°C (32°F) set ZERO Control to Elevation, otherwise set ZERO Control to Suppression.

If the measured temperature starts (below 0°C) (or 32°F) follow step E, otherwise skip step E and go to step F.

- E. Apply an input corresponding to the zero input. Rotate the **FINE ZERO** control fully counter-clockwise. Rotate the **COARSE ZERO** switch to a position where the zero level just goes above 4.00 ma output. Rotate the **COARSE ZERO** switch back one number less than the previous position (but not less than zero). Skip to step G.
- F. Apply an input corresponding to the zero input. Rotate the **FINE ZERO** control fully clockwise. Rotate the **COARSE ZERO** switch to a position where the zero level just goes below 4.00 ma output. Rotate the **COARSE ZERO** switch back one number less than the previous position (but not less than zero).
- G. With the input set at the zero input, adjust the **FINE ZERO** control for 4.00 ma to the desired accuracy.
- H. Apply an input corresponding to the full scale input. Rotate the **FINE SPAN** control fully counterclockwise. Rotate the **COARSE SPAN** switch to a position where the output just exceeds 20.00 ma output. Rotate the switch back one number less (but not less than 0).
- I. With the input set to the full scale input, adjust the fine span control for 20.00 ma to the desired accuracy.
- J. Repeat steps E or F and I until the readings remain within to desired calibration accuracy.
- K. Check the instrument at the 25-50-75% input settings minimum.

WARNING: SUBSTITUTION OF COMPONENTS MAY IMPAIR INTRINSIC SAFETY.

AVERTISSEMENT: LA SUBSTITUTION DE COMPOSANTS PEUT COMPROMETTRE LA SECURITE INTRINSEQUE.

7.0 FIELD TROUBLE SHOOTING GUIDE

This section offers a simple, first level trouble-shooting aid for an apparent instrument malfunction.

SYMPTOM

CORRECTIVE ACTION

- | | |
|-----------|--|
| No output | <ol style="list-style-type: none"> 1. Check the input and output connections carefully. 2. Check that the power supply polarity is correct and that the output loop power is present on the indicated terminals. 3. Check that the input source is correct and that it changes magnitude between zero and full scale values when so adjusted. 4. Make sure the output loop is complete and that the correct meter range is selected. |
|-----------|--|

All external checks are complete. Problem seems to be internal.

The instrument is environmentally sealed. Troubleshooting beyond the above may be difficult without special equipment. We do not recommend attempting repair of the unit in the field. ADTECH offers a very responsive repair policy.

OTHER CONNECTIONS

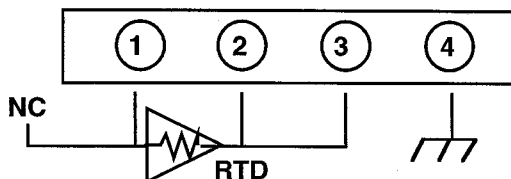

LOOP(+) (-)SUPPLY

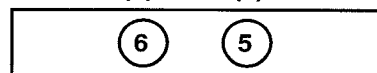

4-WIRE CONNECTION

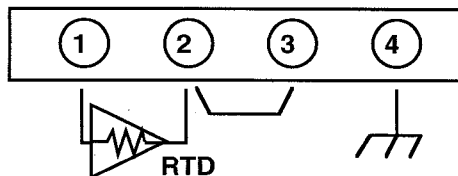

LOOP(+) (-)SUPPLY

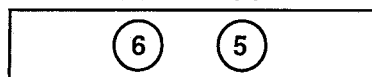

**JUMPER TERMINALS 2 TO 3 FOR
2 WIRE RTD CONNECTION**

8.0 TABLES, OUTLINE / MOUNTING

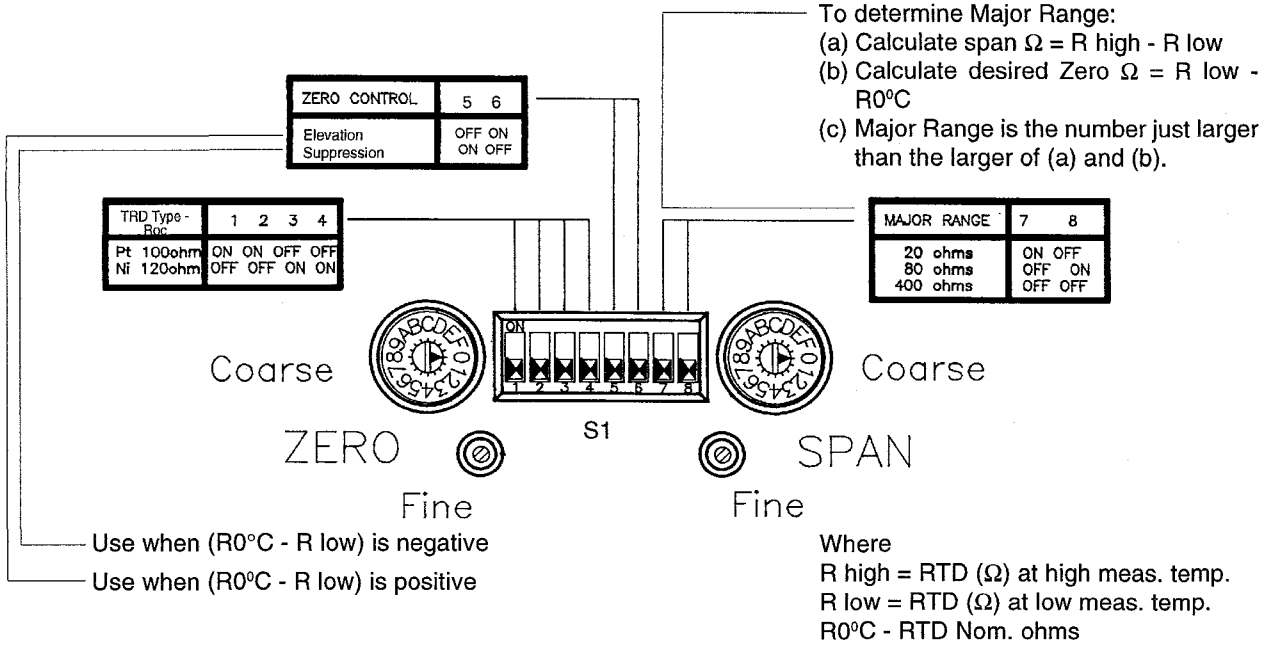

OUTLINE & MOUNTING

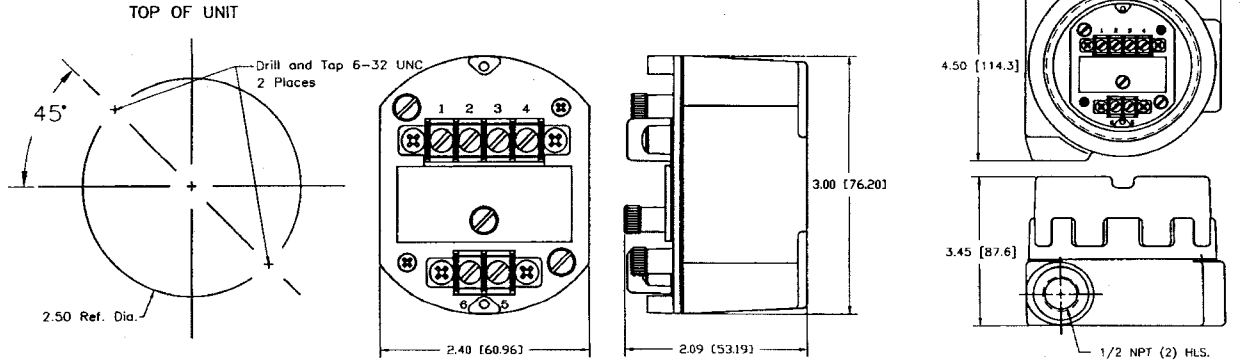

SURFACE MOUNT STANDARD HOUSING

STANDARD HOUSING

EXPLOSION PROOF HOUSING OPTION

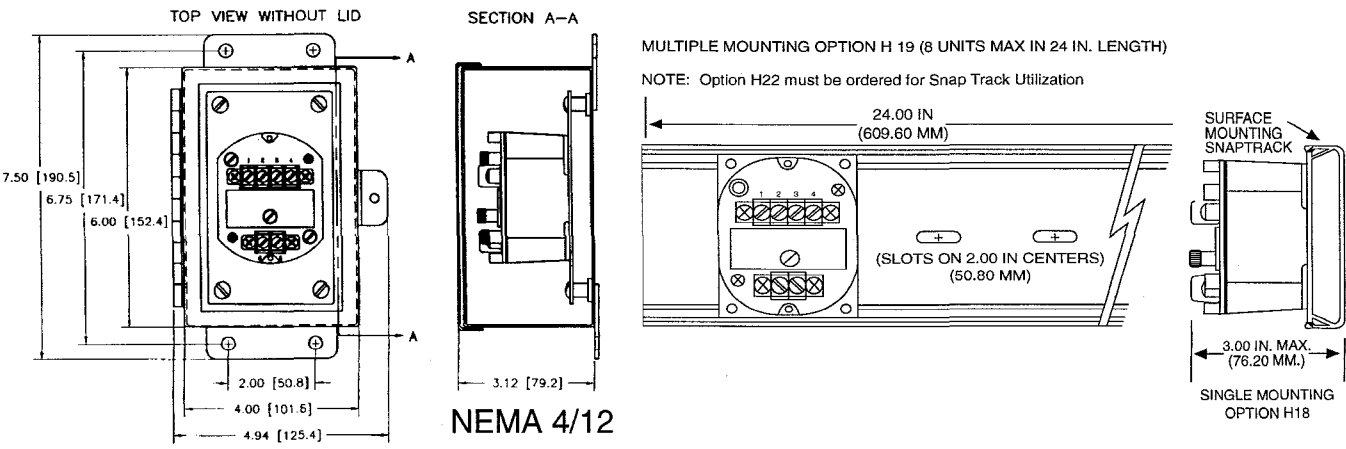

9.0 RBX 174 SPECIFICATIONS

SPECIFICATIONS

INPUT/OUTPUT

INPUT SIGNALS

- a. Resistance bulb sensor: 2, 3, or 4 wire types.
- b. Conformance to RTD curves: 0.15% maximum
- c. 1 to 400 ohm resistance spans: standard
- d. Zero Suppression: up to 100% of the major range selected in 16 divisions of the coarse zero adjustment switch.
- e. Span: from 0 - 100% full scale—switch selectable. The coarse span switch adds 16 divisions to each major range.
- f. Thermistor inputs: optional.
- g. Lead Compensation: 1% maximum error of differential lead resistance.

OUTPUT SIGNAL

- a. 4-20 ma dc

OUTPUT LOOP DRIVE CAPABILITY

$$R(\text{ohm}) = \frac{(V \text{ supply} - V \text{ minimum})1000}{I \text{ out max. ma}}$$

V minimum = 8.0 vdc

I out	4 - 20 ma			
V supply	12	24	36	42
R (ohm)	200	800	1400	1700

PERFORMANCE

- a. **Calibrated Accuracy:** ± 0.1%
- b. **Independent Linearity:** ± 0.025% maximum, ± 0.01% typical
- c. **Repeatability:** ± 0.005% maximum, ± 0.002% typical
- d. **Zero TC:** $\pm \left(\frac{0.05}{\text{input span (ohms)}} + 0.005 \right)$ % of span/°C max.
- e. **Span TC:** ± 0.008% of span max/°C
- f. **Conformance to RTD Curves:** 0.15% maximum
- g. **Load Effect:** ± 0.005% zero to full load
- h. **Output Ripple:** 10 mv P/P maximum
- i. **Response Time:** 110 milliseconds (10 to 90% step response)
- j. **Bandwidth:** (-3 db): 3.2 Hz
- k. **Temperature Range:** -25° to 185°F (-31° to 85°C) operating
-40° to 200°F (-40° to 93°C) storage
- l. **Power Supply Effect:** ± 0.005% over operating range

Note: All accuracies are given as a percentage of span

POWER

- a. 8 to 42 vdc—standard

MECHANICAL

- a. Electrical Classification: general purpose, CSA pending
- b. Connection: Barrier terminal strips
(0.325" spacing, No. 6 screws)
- c. Controls: One 8 position dip switch for major range
Two 16 position rotary switches for **COARSE ZERO** and SPAN control
Two multiturn potentiometers for **FINE ZERO** and SPAN control
- d. Mounting: Surface, Snap-Track, DIN or NEMA 4, 7 & 12
- e. Weight: Net Unit: 8 oz. (228 grams)
Shipping: Nominal 1 pound (455 grams)

OPTIONS

Option Number	Description
H 13 through H 22	Mounting

9.0 RBX 172 SPECIFICATIONS

SPECIFICATIONS

INPUT/OUTPUT

INPUT SIGNALS

- a. Resistance bulb sensor: 2, 3, or 4 wire types.
- b. Conformance to RTD curves: 0.15% maximum
- c. 1 to 400 ohm resistance spans: standard
- d. Zero Suppression: up to 100% of the major range selected in 16 divisions of the coarse zero adjustment switch.
- e. Span: from 0 - 100% full scale—switch selectable. The coarse span switch adds 16 divisions to each major range.
- f. Thermistor inputs: optional.
- g. Lead Compensation: 1% maximum error of differential lead resistance.

OUTPUT SIGNAL

- a. 4-20 ma dc

OUTPUT LOOP DRIVE CAPABILITY

$$R(\text{ohm}) = \frac{(V \text{ supply} - V \text{ minimum})1000}{I \text{ out max. ma}}$$

V minimum = 8.0 vdc

I out	4 - 20 ma			
V supply	12	24	36	42
R (ohm)	200	800	1400	1700

PERFORMANCE

- a. **Calibrated Accuracy:** ± 0.1%
- b. **Independent Linearity:** ± 0.025% maximum, ± 0.01% typical
- c. **Repeatability:** ± 0.005% maximum, ± 0.002% typical
- d. **Zero TC:** $\pm \left(\frac{0.05}{\text{input span (ohms)}} + 0.005 \right)$ % of span/°C max.
- e. **Span TC:** ± 0.008% of span max/°C
- f. **Conformance to RTD Curves:** 0.15% maximum
- g. **Load Effect:** ± 0.005% zero to full load
- h. **Output Ripple:** 10 mv P/P maximum
- i. **Response Time:** 110 milliseconds (10 to 90% step response)
- j. **Bandwidth:** (-3 db): 3.2 Hz
- k. **Temperature Range:** -25° to 185°F (-31° to 85°C) operating
-40° to 200°F (-40° to 93°C) storage
- l. **Power Supply Effect:** ± 0.005% over operating range
- m. **Isolation:** Input/output, 600 vdc or 350 vac

Note: All accuracies are given as a percentage of span

POWER

- a. 8 to 42 vdc—standard

MECHANICAL

- a. Electrical Classification: general purpose, CSA pending
- b. Connection: Barrier terminal strips
(0.325" spacing, No. 6 screws)
- c. Controls: One 8 position dip switch for major range
Two 16 position rotary switches for **COARSE ZERO** and SPAN control
Two multiturn potentiometers for **FINE ZERO** and SPAN control
- d. Mounting: Surface, Snap-Track, DIN or NEMA 4, 7 & 12
- e. Weight: Net Unit: 8 oz. (228 grams)
Shipping: Nominal 1 pound (455 grams)

OPTIONS

Option Number	Description
H 13 through H 22	Mounting