



**ADTECH**  
Analog-Digital Technology, Inc.

The Adtech Model No. RBT 74 Non-Isolated Resistance Bulb Transmitter provides accurate conversion of RTD resistance signals to any standard process signal such as 4-20 mA DC, 1-5 VDC, or zero-based outputs. It offers the broadest range of standard and optional input/output available in a resistance bulb transmitter.

Differential temperature measurement is provided at no additional cost.

The RBT 74 employs the latest design and components utilizing proven techniques for superior reliability, accuracy, and serviceability.

It provides standard process current or voltage signals on the output with a maximum of 10 mV P/P output ripple. Also, the RBT 74 offers a convenient way of interfacing RTD sensors to a computer system or other process instrumentation for improved resolution.

Typical RTDs are 1-6% non-linear, depending on the span and type of sensor. An option to the RBT 74 is a continuous linearization of platinum and nickel RTD sensors independent of span. This option allows conformity of  $\pm 0.25\%$  of span to actual temperature input.

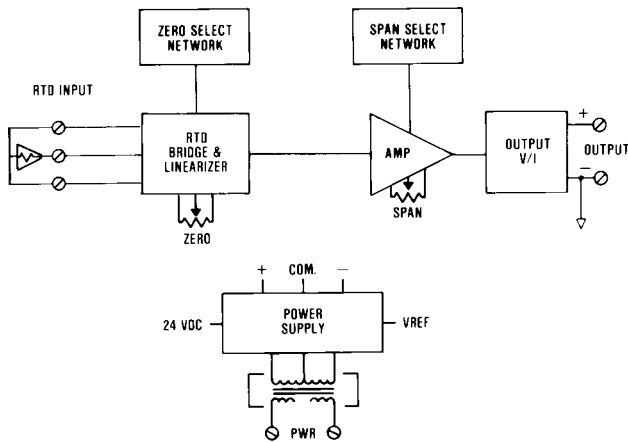

## Features

- **Direct Resistance Bulb Inputs:** Platinum, nickel, copper: 2, 3, or 4 wire
- **Input Spans:** 1.5 ohms to 1,000 ohms--standard
- **Lead Wire Compensation:** 3 or 4 wire-type sensors; constant current excitation (linearization--optional)
- **DC Process Signal Outputs:** Current and voltage
- **Repeatability:**  $\pm 0.02\%$  of span--typical
- **High Accuracy:**  $\pm 0.1\%$  of span

# Non-Isolated Resistance Bulb Transmitter

**Model No. RBT 74**

## Typical Applications

- **High accuracy temperature measurement**
- **Machinery and process temperature measurement**
- **Differential temperature measurement for heat flow computation**
- **Computer/programmable controller interface**

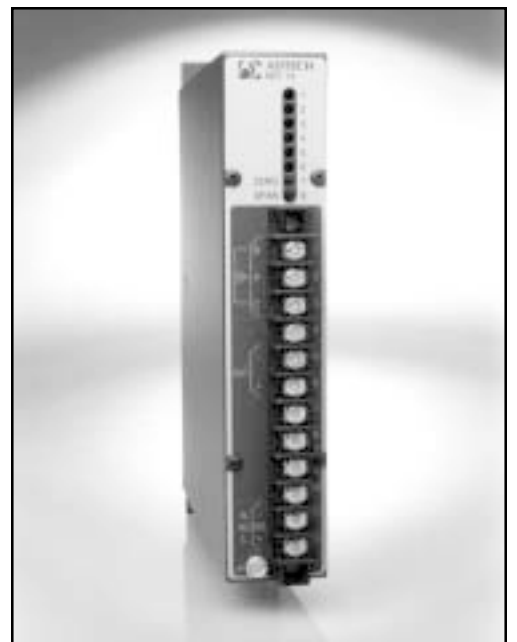

## Connections/Dimensions

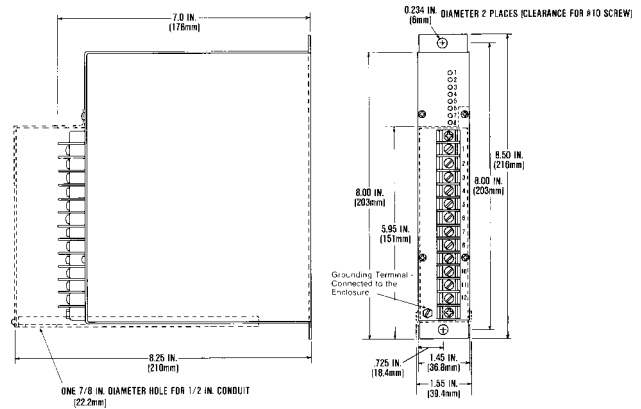
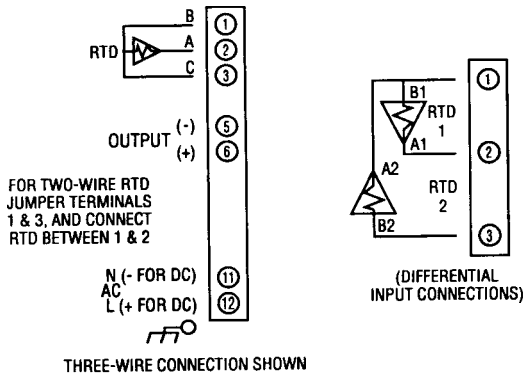

### Input/Output

**Input Signals**  
**Resistance Bulb Sensor:** 2, 3, or 4 wire types and differential sensors  
**1.5 to 1,000 Ohms Resistance**  
**Span:** Standard  
**Higher and Lower Ranges:** Optional

**Output Signals/Output Drive (RL)**

Signal	AC Power (RL)	DC Power (RL)
4-20 mA DC	0-1,000 ohms max.	0-900 ohms max.
10-50 mA DC	0-400 ohms max.	0-350 ohms max.
0-1 mA DC	0-20,000 ohms max.	0-18,000 ohms max.
1-5 VDC	100k ohms min.	100k ohms min.
0-10 VDC	200k ohms min.	200k ohms min.

### Performance

**Calibrated Accuracy:**  $\pm 0.1\%$   
**Linearity:**  $\pm 0.1\%$  maximum,  $\pm 0.04\%$  typical  
**Repeatability:**  $\pm 0.05\%$  maximum  
**Temperature Stability:**  $\pm 0.01\%/^{\circ}\text{F}$  maximum,  $\pm 0.004\%/^{\circ}\text{F}$  typical  
**Load Effect:**  $\pm 0.01\%$  zero to full load  
**Output Ripple:** 10 mV P/P maximum  
**Response Time:** 150 milliseconds  
**Temperature Range:**  $0^{\circ}$  to  $140^{\circ}\text{F}$  ( $-18^{\circ}$  to  $60^{\circ}\text{C}$ ) operating;  $-40^{\circ}$  to  $185^{\circ}\text{F}$  ( $-40^{\circ}$  to  $85^{\circ}\text{C}$ ) storage  
**Power Supply Effect:**  $\pm 0.05\%$  for a  $\pm 10\%$  power variation  
*Note: All accuracies are given as a percentage of span.*

### Power

<b>115 VAC:</b> 50/60 Hz, 0.7 PF (Standard)	<b>48 VDC:</b> Isolated (Option P3)
<b>12 VDC:</b> Isolated (Option P8)	<b>125 VDC:</b> Isolated (105-140 VDC) (Option P4)
<b>24 VDC:</b> Non-isolated (Option P1)	<b>230 VAC:</b> 50/60 Hz, 0.7 PF (Option P5)
<b>24 VDC:</b> Isolated (Option P2)	

*Note: All units 3 watts maximum, and  $\pm 10\%$  power variation unless noted.*

### Mechanical

**Electrical Classification:** General purpose  
**Connection:** Barrier terminal strip (3/8" spacing, No. 6 screws)  
**Controls:** Multiturn zero and span controls  
**Mounting:** Surface mounting standard. See Housings Section for options.  
**Weight:** Net Unit: 2.6 pounds (1.18 kilograms); Shipping: 3.0 pounds (1.36 kilograms)

### Options

Option Number	Description
I 16, I 17	Platinum and nickel linearization
O 10	Bipolar current output (larger than $\pm 1$ mA)
O 11	Bipolar voltage output to $\pm 10$ VDC: at 1 mA, bipolar current $\pm 1$ mA
H 10	Thin-line conduit mounting plate and terminal cover
H 13B, H 14B, H 15B	NEMA 4, 7, and 12 enclosures
H 16	PFA 12 high-density, plug-in enclosures

#### Ordering Information

- Model number
- Input sensor type and temperature coefficient
- Input temperature range (Degrees "F" or degrees "C")
- Output signal
- Input/output options such as linearization
- Prime power with option no.
- Housing and miscellaneous options

*Please refer to the Housing and/or Option Section for more specific and detailed information.*

### Represented by:



**Analog-Digital Technology, Inc.**  
 3750 Monroe Avenue  
 Pittsford, New York 14534-1302  
 Phone: (716) 383-8280  
 Fax: (716) 383-8386  
 E Mail: adtech@adtech-inst.com  
 Web site: http://www.adtech-inst.com

Information subject to change without notice.