



ADTECH
Analog-Digital Technology, Inc.

The Adtech Model RBT 72 Isolated Resistance Bulb Transmitter provides accurate conversion of RTD resistance signals to any standard process signal such as 4-20 mA DC, 1-5 VDC, or zero-based outputs. It offers the broadest range of standard and optional input/output available in a resistance bulb transmitter.

Differential temperature measurement is provided at no additional cost.

Digital processing with optical isolation is utilized for improved linearity, stability, and response. The RBT 72 delivers superior performance and isolation levels, high common mode rejection, high input impedance, accuracy, and temperature stability.

Features include 600 VAC/1,000 VDC isolation with a common mode rejection of 140 db at 60 Hz.

The RBT 72 provides standard process current or voltage signals on the output with a maximum of 10 mV P/P output ripple. It offers a convenient way of interfacing RTD sensors to a computer system or other process instrumentation for improved resolution.

Typical RTDs are 1-6% non-linear, depending on the span and type of sensor. An option to the RBT 72 is a continuous linearization of platinum and nickel RTD sensors independent of span. This option allows conformity of $\pm 0.25\%$ of span to actual temperature input.

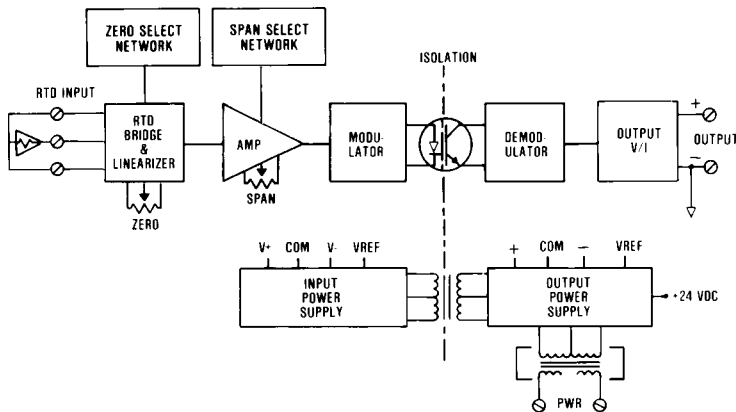

Features

- **Direct Resistance Bulb Inputs:** Platinum, nickel, copper: 2, 3, or 4 wire
- **Input Spans:** 1.5 ohms to 1,000 ohms--standard
- **Lead Wire Compensation:** 3 or 4 wire-type sensors, constant current excitation (linearization--optional)
- **DC Process Signal Outputs:** Current and voltage
- **Repeatability:** $\pm 0.02\%$ of span
- **High Accuracy:** $\pm 0.1\%$ of span
- **Isolation:** 600 VAC/1,000 VDC input to output, 1,500 VAC power

Isolated Resistance Bulb Transmitter

Model No. RBT 72

Typical Applications

- **High accuracy temperature measurement**
- **Machinery and process temperature measurement**
- **Differential temperature measurement for heat flow computation**
- **Computer/programmable controller interface**



Connections/Dimensions

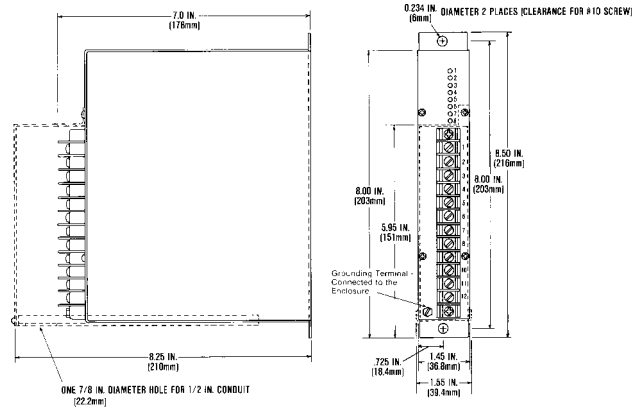
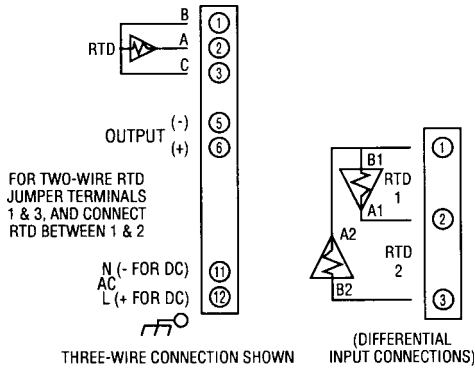

Input/Output

Input Signals

Resistance Bulb Sensor: 2, 3, or 4 wire types and differential sensors

1.5 to 1,000 Ohms Resistance

Spans: Standard

Higher and Lower Ranges: Optional

Output Signals/Output Drive (RL)

Signal	AC Power (RL)	DC Power (RL)
4-20 mA DC	0-1,000 ohms max.	0-900 ohms max.
10-50 mA DC	0-400 ohms max.	0-350 ohms max.
0-1 mA DC	0-20,000 ohms max.	0-18,000 ohms max.
1-5 VDC	100k ohms min.	100k ohms min.
0-10 VDC	200k ohms min.	200k ohms min.

Performance

Calibrated Accuracy: $\pm 0.1\%$

Linearity: $\pm 0.1\%$ maximum, $\pm 0.04\%$ typical

Repeatability: $\pm 0.05\%$ maximum

Temperature Stability: $\pm 0.01\%/^{\circ}\text{F}$ maximum, $\pm 0.004\%/^{\circ}\text{F}$ typical

Load Effect: $\pm 0.01\%$ zero to full load

Output Ripple: 10 mV P/P maximum

Response Time: 150 milliseconds

Temperature Range: 0° to 140°F (-18° to 60°C) operating; -40° to 185°F (-40° to 85°C) storage

Power Supply Effect: $\pm 0.05\%$ for a $\pm 10\%$ power variation

Common Mode Rejection: 140 db @ 60 Hz

Isolation: Input/output/power 600 VAC, 50/60 Hz, 1,000 VDC for AC & isolated DC powered units

Note: All accuracies are given as a percentage of span.

Power

115 VAC: 50/60 Hz, 0.7 PF (Standard)

12 VDC: Isolated (Option P8)

24 VDC: Non-isolated (Option P1)

24 VDC: Isolated (Option P2)

48 VDC: Isolated (Option P3)

125 VDC: Isolated (105-140 VDC) (Option P4)

230 VAC: 50/60 Hz, 0.7 PF (Option P5)

Note: All units 3 watts maximum, and $\pm 10\%$ power variation unless noted.

Mechanical

Electrical Classification: General purpose

Connection: Barrier terminal strip (3/8" spacing, No. 6 screws)

Controls: Multiturn zero and span controls

Mounting: Surface mounting standard. See Housings Section for options.

Weight: Net Unit: 2.6 pounds (1.18 kilograms); Shipping: 3.0 pounds (1.36 kilograms)

Options

Option Number

I 16, I 17

O 10

O 11

O 12

H 10

H 13B, H 14B, H 15B

H 16

Description

Platinum and nickel linearization

Bipolar current output (larger than ± 1 mA)

Bipolar voltage output to ± 10 VDC: at 1 mA, bipolar current ± 1 mA

Reverse calibration

Thin-line conduit mounting plate and terminal cover

NEMA 4, 7, and 12 enclosures

PFA 12 High-density, plug-in enclosures

Ordering Information

- Model number
- Input sensor type and temperature coefficient
- Input temperature range (Degrees "F" or degrees "C")
- Output signal
- Input/output options such as linearization
- Prime power with option no.
- Housing and miscellaneous options

Please refer to the Housing and/or Option Section for more specific and detailed information.

Represented by:



Analog-Digital Technology, Inc.
3750 Monroe Avenue
Pittsford, New York 14534-1302

Phone: (716) 383-8280

Fax: (716) 383-8386

E Mail: adtech@adtech-inst.com

Web site: <http://www.adtech-inst.com>

Information subject to change without notice.

Printed in U.S.A.

A038