



1.0 INTRODUCTION

These instructions refer to the above model. Supplementary sheets are attached if the unit has special options or features. For detailed specifications, see page 4 or refer to the Data Bulletin. All ADTECH instruments are factory calibrated and supplied with a label detailing the calibration. Adjustments are normally not necessary. A simple check should be performed to verify calibration before installation to ensure that it matches the field requirement.

2.0 GENERAL DESCRIPTION

The ADTECH RBT 72 is an Isolated Resistance Bulb Transmitter that accepts a RTD Resistance input signal of 10-1,000 ohms and converts it into any of the standard control signal outputs such as 4-20 ma dc.

The input is electrically isolated from the output and the power supply by 600 volts ac or 1000 vdc peak on AC powered and isolated DC powered units. Power option P-1 Non-Isolated 24 vdc provides negative output signal and negative DC power common rail connection.

The output is a true current source and provides process signals such as 4-20 ma, 0-1 ma, 0-10 ma, 1-5 ma and 10-50 ma dc or alternatively, a voltage signal of 5 vdc full scale. Other current and voltage **Inputs/Outputs (I/O)** are available as specified on the Data Bulletin.

3.0 INSTALLATION

The instrument is supplied in a general purpose enclosure as standard. NEMA 4, 7 or 12 and plug in chassis enclosures are optionally available. Installation area/location must agree with the supplied instruments including operating temperature and ambient conditions.

Mounting

Refer to the appropriate outline drawing for mounting and clearance dimensions. The instrument is surface mounted with two #10-32 screws on 8.00 inch centers.

Electrical Connections

The wire used to connect the instrument to the control system I/O should be a twisted pair(s) and sized according to normal practice. Shielded cable is not normally necessary (if used, the shield must be grounded at the input of the ADTECH instrument and left floating at the sensor).

A 12 position barrier terminal block with #6-32 screws and 3/8" spacing is provided for I/O and power connection. A housing ground terminal marked G is also provided.

Controls

Multiturn ZERO and SPAN controls are provided to calibrate the instrument. The multiturn controls are accessible through the instrument front panel and are clearly marked for ease of use.

4.0 MAINTENANCE

These instruments are electronic and require no maintenance except periodic cleaning and calibration verification. If the unit appears to be mis-operating it should be checked as installed per section 6.0 or removed for a bench check per sections 6.0-7.0. MOST problems are traced to field wiring and/or associated circuits. If the problem appears to be with the instrument, proceed to sections 6.0 and 7.0.

5.0 CONNECTIONS

Standard connections are shown below and on the instrument face plate, Data Bulletin or on attached supplementary sheets.

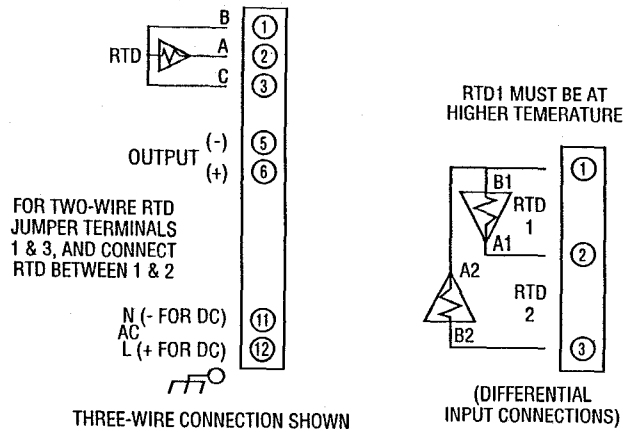

6.0 CALIBRATION

To perform a calibration check or re-calibration of the instrument follow this procedure.

- A. Make sure the unit I/O wiring is properly connected and that the correct power source per the label is also connected. The instrument must be at normal power for a minimum of 2 minutes before proceeding to B.
- B. The input signal source(s) must be adjustable from 0 to 100% in steps of 10% or at least 25%. The source(s) should be either precalibrated or an accurate meter must be used to monitor the input(s).
- C. The output may be monitored either as a direct voltage for a voltage output signal or as a current that can be represented as a voltage across a resistor shunt for a current output signal.
- D. Set the input source to minimum input value and adjust the multiturn potentiometer marked ZERO to provide the minimum calibrated output (e.g.) 4.00 ma \pm 0.01 ma dc.
- E. Set the input source to maximum value and adjust the multiturn potentiometer marked SPAN to provide the maximum calibrated output (e.g.) 20.00 ma \pm 0.12 ma dc.
- F. Repeat steps D and E until readings are within calibration.
- G. The instrument should now be checked at 25-50-75% of span minimum.
- H. This completes the calibration.

NOTE:

If recalibration to a different input and/or output signal is required, proceed to the tables listed under Section 8.0.

7.0 FIELD TROUBLE SHOOTING GUIDE

This section offers a simple, first level trouble-shooting aid for an apparent instrument malfunction.

SYMPTOM

CORRECTIVE ACTION

- No output
1. Check the input and output connections carefully.
 2. Check that the power supply polarity is correct and that power is present on the instrument terminals.
 3. Check that the input source(s) is correct and that it changes magnitude between zero and full scale values when so adjusted.
 4. If the output is a current signal (4-20 ma, etc.), make sure the output loop is complete and that the correct meter range is selected.

All external checks are complete. Problem seems to be internal.

The following information is provided for a qualified technician or serviceman as check points for use in internal troubleshooting.

<u>CHECKPOINT/ COMPONENT</u>	<u>VOLTAGE/ RANGE</u>
(across) C9	10.5 \pm 0.5 vdc
(across) C11	10.5 \pm 0.5 vdc
(across) C16	12 \pm 0.6 vdc
(across) C18	26 \pm 4 vdc
(from 0 V) +VR	+ 6.9 \pm 0.35 vdc
(across) R100	0.2 to 1.0 vdc
(from 0 V) J12	6.9 V p-p rect. pulse wave form

8.0 TABLES, PCB LAYOUT

ZERO OFFSET COARSE TABLE

R(Z)**	R88	R89	R90	R91	R92
90	X	X	-	X	-
100	-	X	X	X	-
110	-	X	X	-	X
120	X	X	-	-	-
130	X	-	X	-	-
140	-	X	X	-	-
152	X	-	-	-	X
160	-	-	X	X	-
167	-	X	-	-	X

(X) = Present (-) = Absent

**See notes below.

ZERO OFFSET FINE TABLE

R(Z)**	R70	R71	R72	R73
0.0	X	X	X	X
2.5	X	-	-	-
5.0	-	X	-	X
7.5	-	-	X	-
10.0	-	-	X	X

(X) = Present (-) = Absent

SPAN TABLE

SPAN (OHMS)	R83	R82	R28	R29	R30	R31	ZERO POT RANGE
*3.3 - 6.6	X	X	X	X	X	X	2.0
*6.6 - 10.0	X	X	X	X	X	-	4.0
10 - 20.0	-	X	X	X	X	X	6.6
20 - 40	-	X	X	X	X	-	13.2
40 - 80	-	X	X	X	-	-	26.4
80 - 160	-	X	X	-	-	-	53
160 - 320	-	X	-	-	-	-	100
320 - 640	-	-	X	X	X	X	106
640 - 1300	-	-	X	X	X	-	210
1.3 - 2.5K	-	-	X	X	-	-	420
2.5 - 5.0K	-	-	X	-	-	-	840
5.0 - 10.0K	-	-	-	-	-	-	1600

(X) = Present (-) = Absent

NOTE A: Components as shown may or may not be present on the p.c. board due to design updates or options.

OUTPUT TABLE

OUTPUT SIGNAL FULL SCALE	OUTPUT SHUNT RL	FEEDBACK RES RF
50 ma dc	NONE	20 ohm
20 ma dc	NONE	49.9 ohm
10 ma dc	NONE	100 ohm
1 ma dc	NONE	1K ohm
10 vdc	604 ohm, 1/4 W	49.9 ohm
5 vdc	250 ohm, 1/2 W	49.9 ohm

All selected resistors are 1%, M.F., 1/4 W, 50 PPM, unless otherwise noted.

RBT 72

RL = R106

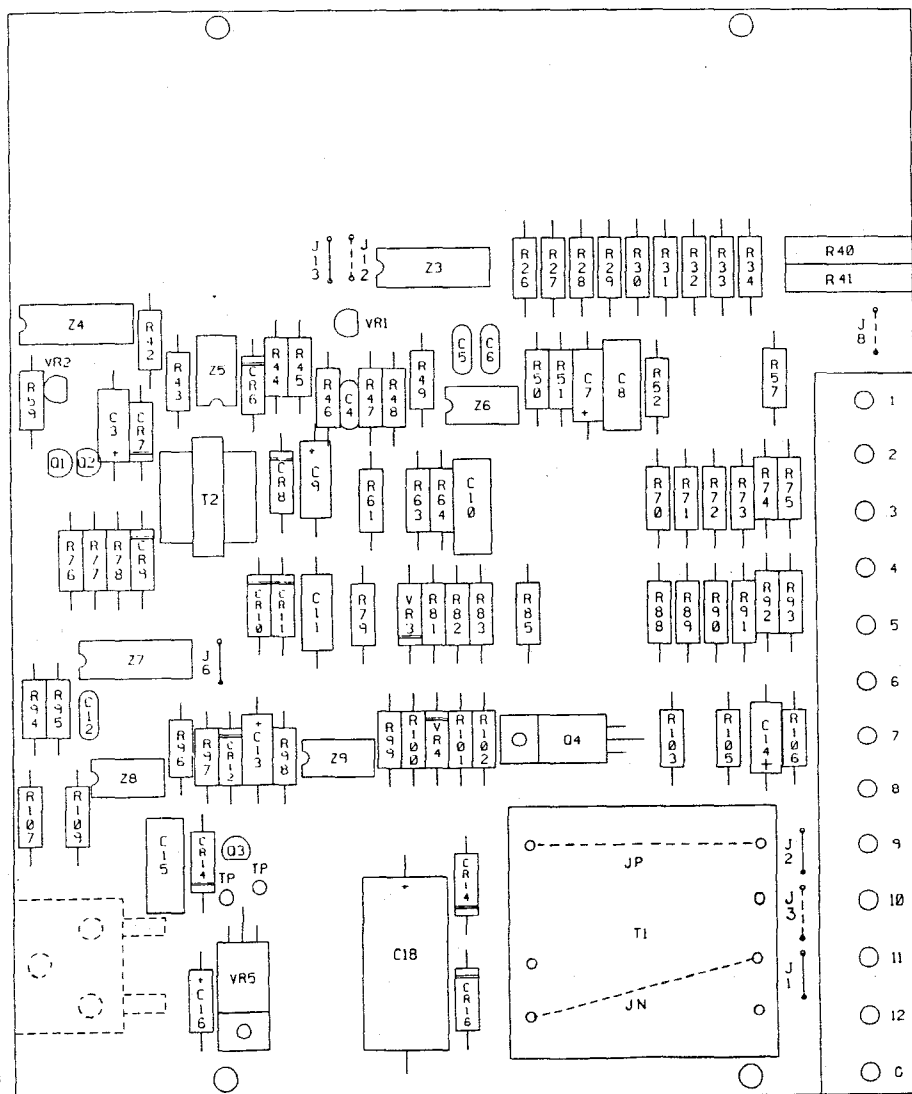

NOTES:

1. Calculate the Ohm value of the input SPAN (ie.) (RTD maximum - RTD minimum) = SPAN Ohms.
2. Select the appropriate jumpers from the SPAN TABLE and note the corresponding Zero Pot Range value.
3. Zero Offset tables are selected by calculating $R(Z) = RTD \text{ minimum} - 1/2 \text{ (ZERO POT RANGE)}$.
4. R(Z) must be selected using the Coarse plus Fine Zero Offset Tables and their sum must be just below the R(Z) Ohm Value calculated in step 3.0.
5. If R(Z) value falls between 170-250 ohms, change R74 to 100 ohm. Select the coarse and fine table resistors to provide sum of ohms = $R(Z) - 80$. If R(Z) value falls between 250-330 ohms, change R74 to 182 ohms, R75 to 1.21 kohm. Select the coarse and fine table resistors to provide sum of ohms = $R(Z) - 160$.
6. If the R(Z) is less than 90 ohms select the coarse and fine table resistors to provide 90 ohms.
7. If the RTD minimum is less than 90 ohms delete JR57 and add R56 = 90 ohm - RTD minimum using the coarse and fine tables to provide 90 ohms.
8. All selected resistors are 1/4W, 1%, 25 PPM.

9.0 SPECIFICATIONS

INPUT/OUTPUT

INPUT SIGNALS

- Resistance bulb sensor: 2, 3, or 4 wire types and differential sensors
- 10 to 1,000 ohm resistance spans: standard
- 1.5 ohm to 9.9 ohm resistance spans: optional
- Higher and lower ranges: optional
- Thermistor inputs: optional

OUTPUT SIGNALS

- | | AC Power | DC Power |
|----------------|--------------------|--------------------|
| a. 4-20 ma dc | 0-1000 ohms max. | 0-900 ohms max. |
| b. 10-50 ma dc | 0-400 ohms max. | 0-350 ohms max. |
| c. 0-1 ma dc | 0-20,000 ohms max. | 0-18,000 ohms max. |
| d. 1-5 vdc | 250 ohms Z out | 250 ohms Z out |
| e. 0-10 vdc | 500 ohms Z out | 500 ohms Z out |
- Zero based current and voltages in the above ranges are standard (e.g.) 0-20 ma, 0-5 vdc. Other voltage and currents optional.

PERFORMANCE

- Calibrated Accuracy:** $\pm 0.1\%$
- Linearity:** $\pm 0.1\%$ maximum, $\pm 0.04\%$ typical
- Repeatability:** $\pm 0.05\%$ maximum
- Temperature Stability:** $\pm 0.01\%/^{\circ}\text{F}$ maximum, $\pm 0.004\%/^{\circ}\text{F}$ typical
- Load Effect:** $\pm 0.01\%$ zero to full load
- Output Ripple:** 10 mv P/P maximum
- Response Time:** 150 milliseconds
- Temperature Range:** 0° to 140°F (-18° to 60°C) operating
 -40° to 185°F (-40° to 85°C) storage
- Power Supply Effect:** $\pm 0.05\%$ for a $\pm 10\%$ power variation
- Common Mode Rejection:** 140 db @ 60 Hz
- Isolation:** Input/output/power 600 vac, 50/60 Hz, 1000 vdc for AC and isolated DC powered units

Note: All accuracies are given as a percentage of span

POWER

- 115 vac: $\pm 10\%$, 50/60 Hz, 3 watts, 0.7 Pf (standard)
- 24 vdc: $\pm 10\%$ non-isolated, 3 watts (Option P1)
- 24 vdc: $\pm 10\%$ isolated, 3 watts (Option P2)
- 48 vdc: $\pm 10\%$ isolated, 3 watts (Option P3)
- 125 vdc: Nominal (105-140 vdc) isolated, 3 watts (Option P4)
- 230 vac: $\pm 10\%$, 50/60 Hz, 3 watts, 0.7 PF (Option P5)

10.0 OUTLINE & MOUNTING

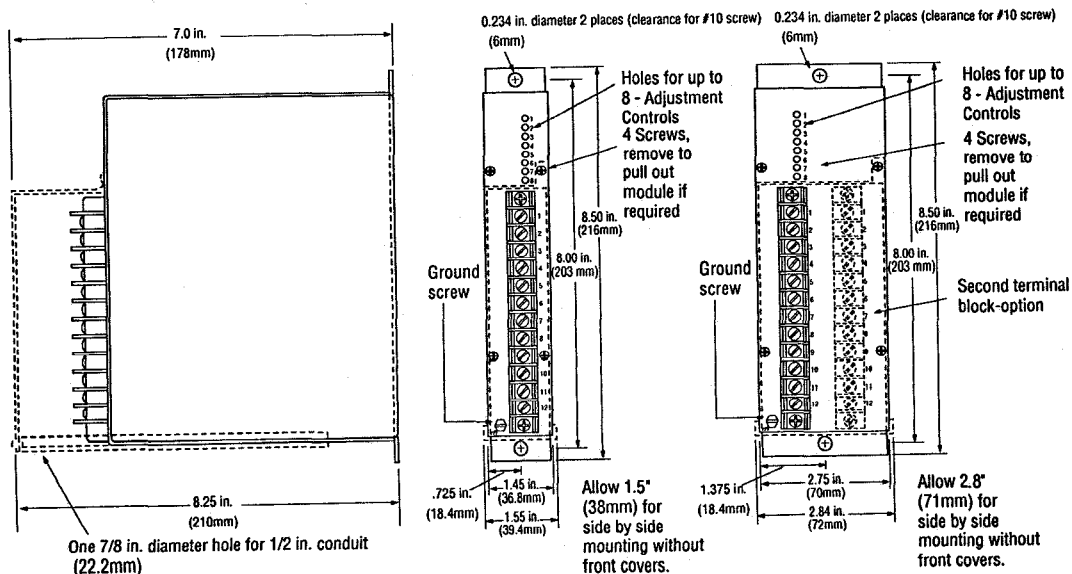

6.0 CALIBRATION

To perform a calibration check or re-calibration of the instrument follow this procedure.

- A. Make sure the unit I/O wiring is properly connected and that the correct power source per the label is also connected. The instrument must be at normal power for a minimum of 2 minutes before proceeding to B.
- B. The input signal source(s) must be adjustable from 0 to 100% in steps of 10% or at least 25%. The source(s) should be either precalibrated or an accurate meter must be used to monitor the input(s).
- C. The output may be monitored either as a direct voltage for a voltage output signal or as a current that can be represented as a voltage across a resistor shunt for a current output signal.
- D. Set the input source to minimum input value and adjust the multiturn potentiometer marked ZERO to provide the minimum calibrated output (e.g.) 4.00 ma \pm 0.01 ma dc.
- E. Set the input source to maximum value and adjust the multiturn potentiometer marked SPAN to provide the maximum calibrated output (e.g.) 20.00 ma \pm 0.12 ma dc.
- F. Repeat steps D and E until readings are within calibration.
- G. The instrument should now be checked at 25-50-75% of span minimum.
- H. This completes the calibration.

NOTE:

If recalibration to a different input and/or output signal is required, proceed to the tables listed under Section 8.0.

7.0 FIELD TROUBLE SHOOTING GUIDE

This section offers a simple, first level trouble-shooting aid for an apparent instrument malfunction.

SYMPTOM CORRECTIVE ACTION

- | | |
|-----------|--|
| No output | <ol style="list-style-type: none">1. Check the input and output connections carefully.2. Check that the power supply polarity is correct and that power is present on the instrument terminals.3. Check that the input source(s) is correct and that it changes magnitude between zero and full scale values when so adjusted.4. If the output is a current signal (4-20 ma, etc.), make sure the output loop is complete and that the correct meter range is selected. |
|-----------|--|

All external checks are complete. Problem seems to be internal.

The following information is provided for a qualified technician or serviceman as check points for use in internal troubleshooting.

<u>CHECKPOINT/ COMPONENT</u>	<u>VOLTAGE/ RANGE</u>
(across) C9	10.5 \pm 0.5 vdc
(across) C11	10.5 \pm 0.5 vdc
(across) C16	12 \pm 0.6 vdc
(across) C18	26 \pm 4 vdc
(from 0 V) +VR	+ 6.9 \pm 0.35 vdc
(across) R100	0.2 to 1.0 vdc
(from 0 V) J12	6.9 V p-p rect. pulse wave form