

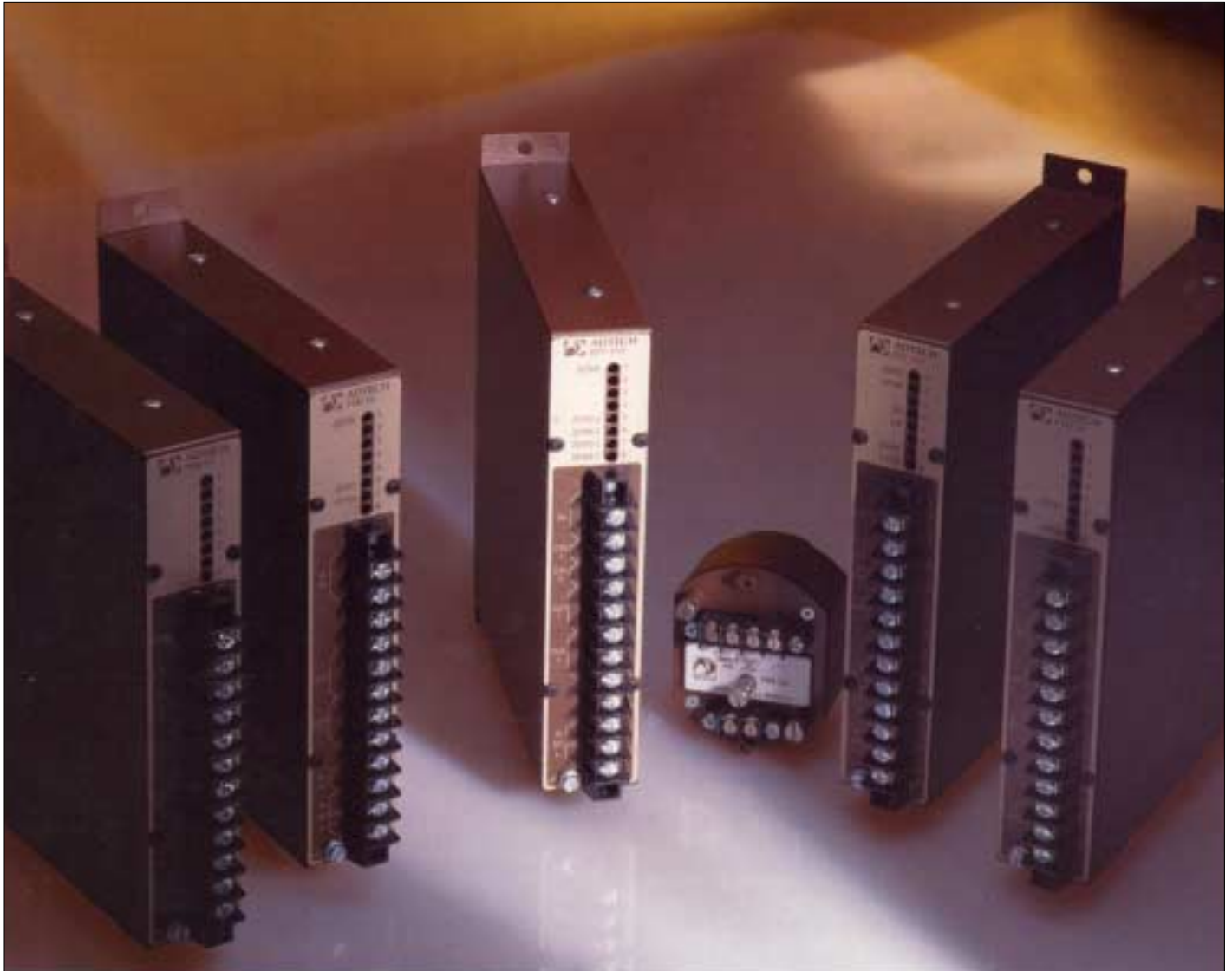

**ADTECH**  
Analog-Digital Technology, Inc.

## Isolated Frequency to D.C. Transmitter

**Model No. MPF 650**



### Features

- **Types of Inputs:** Sine, square wave, or contact closure
- **Inputs: Voltage, or Contact with Adjustable Sensitivity:** Turbine/flowmeter, tach/speed
- **Absolute Frequency Measurement**
- **Frequency Deviation Measurement**
- **Frequency Rate of Change:** Of absolute or deviation
- **Input Voltage Range:** 10 mV to 150 V rms
- **Input Frequency Range:** 0 to 0.031 Hz to 0 to 100 k Hz:  
3,000,000:1
- **Response Time:** 1 period up to 64 Hz
- **Built-in Crystal Calibration Reference**
- **Resolution:**  $\pm 0.05\%$  max.
- **Repeatability:**  $\pm 0.05\%$  max.
- **High Accuracy:**  $\pm 0.1\%$  of span
- **Isolation:** 600 VAC/ 1,000 VDC input to output to power

### Typical Applications

#### Absolute Frequency

- Flow measurement
- Machine speed
- Power frequency
- Energy management
- Watt-hour pulse rate

#### Frequency Deviation

- Utility line monitoring
- Generation control
- Load shed relay
- High resolution and accuracy of operation speed

#### Rate of Change

- Load shed relay
- Machine acceleration

## ABSOLUTE FREQUENCY

### Input/Output

#### Input Signals

**Voltage:** 10 mV to 150 V rms; specify; Input impedance 100 k  $\Omega$   
**Contact:** Dry, 2 mA @ 24 VDC rating; specify  
**Frequency Range:** 0.031 Hz full scale to 100 k Hz full scale; field selectable

#### Output Signals

**Absolute Frequency:** Standard  
**Optional Second Output:** Rate of frequency change (Option O 64). See "Common Specs" below.

## FREQUENCY DEVIATION

(Option I 54)

### Input/Output

#### Input Signals

**Voltage:** 10 mV to 150 V rms; specify; Input impedance 100 k  $\Omega$   
**Contact:** Dry, 2 mA @ 24 VDC rating; specify  
**Reference Frequencies:** 25 Hz, 50 Hz, 60 Hz, 400 Hz; specify  
**Frequency Deviation:**  $\pm 0.39\%$  min. to  $\pm 50\%$  maximum of reference frequency

#### Output Signals

**Frequency Deviation Output:**  
Ranges:  $0.390625 \cdot 2^I$  % F.S. reference I = 0 to 7 field selectable  
**Optional Second Output:** Rate of frequency change (Option O 64) See "Common Specs" below.

4-20 mA DC 0-750 ohms max.  
1-5 VDC 250 ohms Z out  
Other zero-based, bipolar current and voltages are available.

### Performance

**Calibrated Accuracy:**  $\pm 0.1\%$   
**Resolution:**  $\pm 0.025\%$  (12 bit)  
**Linearity:**  $\pm 0.05\%$  maximum,  $\pm 0.02\%$  typical  
**Repeatability:**  $\pm 0.05\%$  maximum  
**Temperature Stability:**  $\pm 0.008\%/^{\circ}\text{F}$  maximum,  $\pm 0.004\%/^{\circ}\text{F}$  typical  
**Temperature Range:** 0° to 140°F (-18° to 60°C) operating; -40° to 185°F (-40° to 85°C) storage

**Load Effect:**  $\pm 0.01\%$  zero to full load  
**Response Time:** One period response up to 64 Hz  
31 msec. max. above 64 Hz.  
**Power Supply Effect:**  $\pm 0.05\%$  for a  $\pm 10\%$  power variation  
**Common Mode Rejection:** 140 db @ 60 Hz  
**Isolation:** Input/output/power 600 VAC, 50/60 Hz, 1,000 VDC for AC and isolated DC power units  
*Note: All accuracies are given as a percentage of range.*

### Rate of Change (Option O 64)

#### Power

**Resolution For Rate of Change Output:**  $\pm 0.025\%$  (12 bit)

**115 VAC:** 50/60 Hz, 0.7 PF (Standard) **48 VDC:** Isolated (Option P3)  
**12 VDC:** Isolated (Option P8) **125 VDC:** Isolated (105-140 VDC) (Option P4)  
**24 VDC:** Isolated (Option P2) **230 VAC:** 50/60 Hz, 0.7 PF (Option P5)  
*Note: All units 3 watts maximum, and  $\pm 10\%$  power variation unless noted.*

### Mechanical

**Electrical Classification:** General purpose  
**Connection:** Barrier terminal strip (3/8" spacing, No. 6 screws)  
**Controls:** Multiturn zero, span, and sensitivity controls; two internal 8-position switches; and optional zero-2 and span-2 controls  
**Mounting:** Surface mounting standard. See Housings Section for options.  
**Weight:** Net Unit: 2.6 pounds (1.18 kilograms)  
Shipping: 3.0 pounds (1.36 kilograms)

### Options

Option Number	Description
I 54	Frequency deviation
O 64	Rate of change output
O 65	12 VDC, at 35 mA loop power
H 13, H 14, H 15	NEMA 4, 7, & 12 enclosures
H 16	PFA 12 high-density, plug-in enclosure

The Adtech model MPF 650 is an isolated frequency transmitter that converts absolute frequency or deviation of frequency into a linear DC signal such as 4-20 mA DC. It accepts a periodic waveform from a variety of primary sensors such as turbine meters, positive displacement meter contacts, or magnetic pick-up, and computes absolute frequency.

This measurement is based on the time period (T). The instrument makes precise measurements of the input waveforms' zero crossings (period T) and computes absolute frequency as (1/T).

The MPF 650 can be configured to measure frequency deviation with option I 54 (frequency deviation is measured as the absolute frequency minus an internal reference frequency). The reference frequency is based on a high-stability crystal oscillator.

A rate of change (output-2) option O 64 is available for either the absolute frequency or frequency deviation configuration. The instrument uses two successive samples of the input to calculate the derivative (or rate of change) of the input. A built-in calibration feature allows calibration without an external source.

The MPF 650 uses input anticipating circuits and provides one of the industry's fastest frequency measurement instruments.

For increasing frequency signals, the output increases as the pulse-by-pulse rate increases.

For decreasing frequency signals, the output decreases at a rate that anticipates the next pulse until the output represents the measured frequency.

With the loss of the input frequency signal, the output continues to anticipate a slower frequency until it reaches zero.

The MPF 650 has measurement techniques that produce essentially no ripple (less than 0.02% of range maximum), which eliminates aliasing problems.

The MPF 650 optionally provides 12 VDC at 35 mA to power the sensor. The use of this option O 65 negates the input to output isolation.

The output(s) is (are) true current/voltage source(s). They provide process signals such as 4-20 mA, 0-1 mA, 0-10 mA,  $\pm 1$  mA,  $\pm 10$  mA DC, or alternatively 1-5 V, 0-5 V,  $\pm 5$  V, and  $\pm 10$  V full scale. Other current and voltage outputs are available.

In addition to the MPF 650, Adtech also offers a family of frequency instrumentation, as listed below. See the adjacent column to the right for additional detail.

**FDX 150** Field Selectable-Wide Ranging Two-Wire Transmitter, with a 0-30 to 0-30 k Hz input range.

**FDT 150** Isolated Frequency Transmitter for input spans of 30 Hz minimum to 30 k Hz, 10 mV to 100 V rms.

**FSM 55** Frequency Scaling Module

**PAM 59** Pulse/Frequency Accumulating Module

**PSM 57** Pulse/Frequency Summing-Subtracting Module

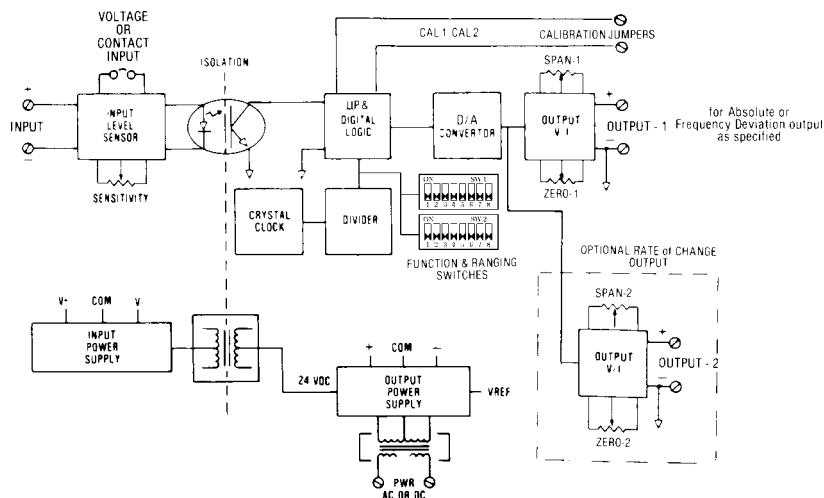

## Other Frequency Instruments

### FDT 150

#### Isolated Frequency to DC Transmitter

- For input spans of 30 Hz minimum to 30 k Hz, 10 MV to 100 V rms maximum
- Contact, pulse or AC waveform
- Flow measurement
- Machine speed measurement

### FSM 55

#### Frequency Scaling Module

- Reading or scaling
- Machine speed scaling
- Turbine meter scaling
- Positive displacement meter scaling
- Linear displacement transducer scaling
- Watt-hour pulse rate scaling

### PAM 59

#### Pulse Accumulating Module Total Number of Pulses to DC Transmitter

- Turbine meter flow totalization
- Positive displacement meter flow totalization
- Watt-hour energy demand totalization
- Energy peak demand computation

### PSM 57

#### Pulse Summing-Subtracting with Scaling Module

- Total flow computation
- Total electric power summation
- Total heat load (BTU's)
- Multiple turbine meter flow scaling and totalization
- Multiple positive displacement meter scaling and totalization
- Multiple watt-hour meter scaling and totalization

## Connections

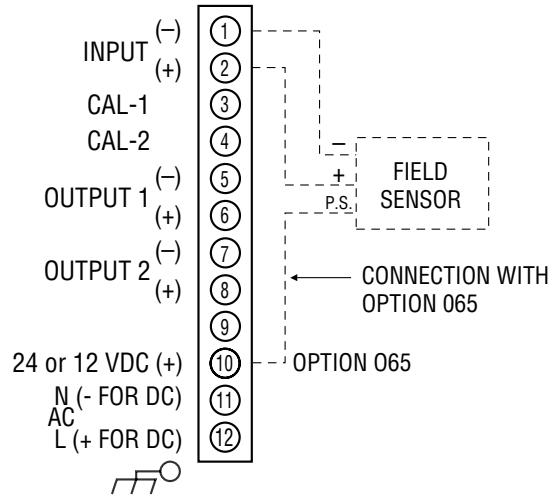

## Dimensions

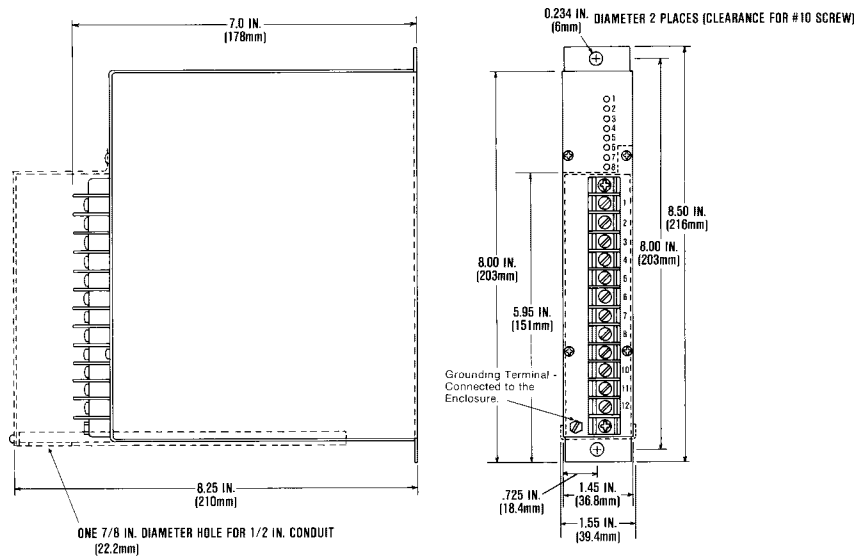

### Ordering Information

- Model number
- Input pulse rate and voltage amplitude
- Pulse or contact input
- Output signal
- Prime power with option no.
- Input/output options
- Housing and miscellaneous options

*Please refer to the Housing and/or Option Section for more specific and detailed information.*



Represented by:



**Analog-Digital Technology, Inc.**  
3750 Monroe Avenue  
Pittsford, New York 14534-1302

Phone: (716) 383-8280  
Fax: (716) 383-8386

E Mail: [adtech@adtech-inst.com](mailto:adtech@adtech-inst.com)  
Web site: <http://www.adtech-inst.com>

Information subject to change without notice.

Printed in U.S.A.

A061