



ADTECH
Analog-Digital Technology, Inc.

The Adtech Model LLM 64 Lead-Lag Module offers an accurate and economical means of producing a phase lead or phase lag between an input current or voltage signal and output process signal, such as 4-20 mA DC, or 1-5 VDC. It utilizes precise digital techniques to do this function.

In the lead mode, a step input produces a fast rise (or fall) wave form with a gain of 10, then the output decays like an RC response toward the steady state output level. In the lag mode, a step input produces an output typical of a single pole low pass filter.

The LLM 64 provides standard process current or voltage signals on the output with a maximum of 10 mV P/P output ripple.

Recalibration to other desired ranges is accomplished easily. The use of temperature-stable, low-noise components provides excellent stability and noise immunity.

The LLM 64 employs the latest digital and analog design and components utilizing proven techniques for superior reliability, accuracy, and serviceability.

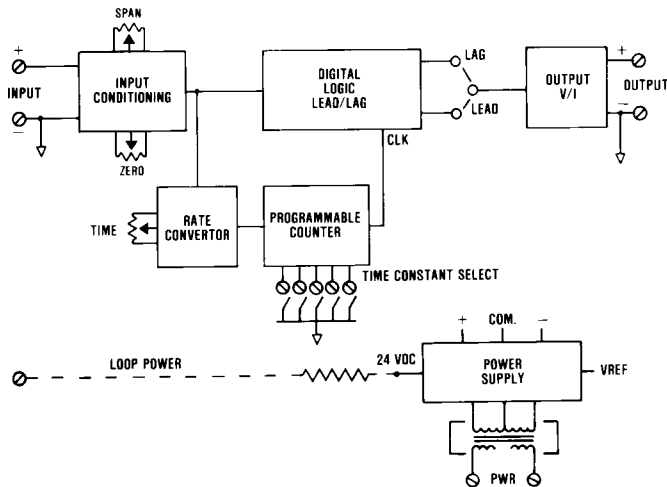

Features

- **Lead-Lag Ranges:** 1 second to 50 hours
- **Lead-Lag Mode:** Strap selectable
- **Low-Pass Filter or Signal Averager:** 2.5 micro Hz to 5 Hz adjustable
- **DC Current Inputs:** 4-20 mA, etc.
- **DC Voltage Inputs:** 1-5 VDC, etc.
- **High-Input Impedance:** 10 megohms minimum
- **Zero-based Inputs:** Current and voltage
- **DC Process Signal Outputs:** Current and voltage
- **Repeatability:** $\pm 0.02\%$ of span typical
- **High Accuracy:** $\pm 0.1\%$ of span

Lead-Lag Module

Model No. LLM 64

Typical Applications

- **Process feedforward and feedback control**
- **Response restriction of actuator motors**
- **Recorder pen noise reduction**
- **Rate-of-change computer**

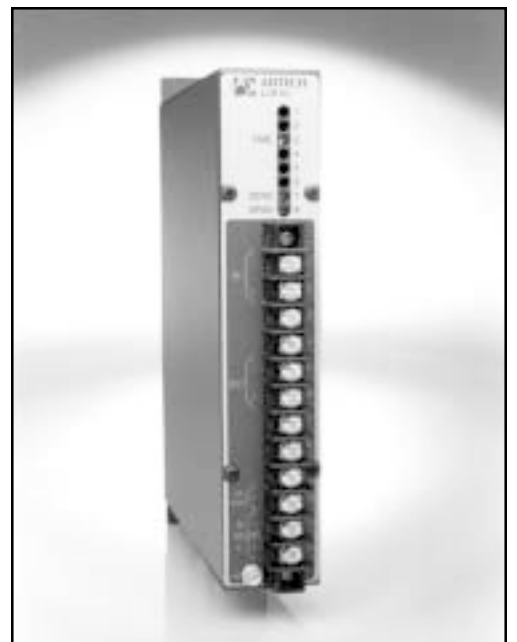

Connections/Dimensions

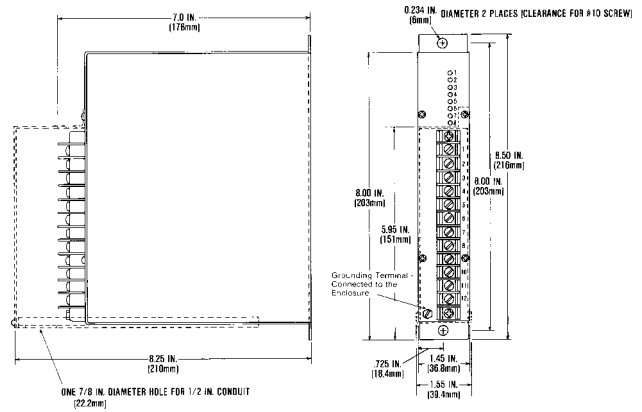
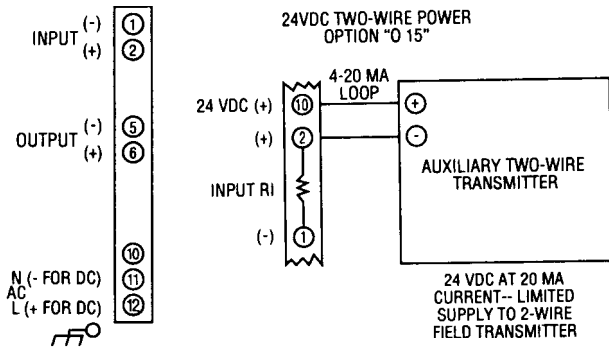

Input/Output

Input Signals

4-20 mA DC (Z in 250 ohms)
10-50 mA DC (Z in 100 ohms)
0-1 mA DC (Z in 5k ohms)
0-10 mA DC (Z in 500 ohms)
1-5 VDC (Z in 10 megohms)
0-5 VDC (Z in 10 megohms)
0-10 VDC (Z in 1 megohm)
Other zero-based current and voltages are available.
Contact closure--standard unit only.

Output Signals/Output Drive (RL)

Signal	AC Power (RL)	DC Power (RL)
4-20 mA DC	0-1,000 ohms max.	0-900 ohms max.
10-50 mA DC	0-400 ohms max.	0-350 ohms max.
0-1 mA DC	0-20,000 ohms max.	0-18,000 ohms max.
1-5 VDC	100k ohms min.	100k ohms min.
0-10 VDC	200k ohms min.	200k ohms min.

Ramp Ranges: Specify time constant.

Performance

Calibrated Accuracy: $\pm 0.1\%$
Linearity: $\pm 0.1\%$ max., $\pm 0.04\%$ typical
Repeatability: $\pm 0.05\%$ maximum
Temperature Stability: $\pm 0.01\%/^{\circ}\text{F}$ max.,
 $\pm 0.004\%/^{\circ}\text{F}$ typical
Load Effect: $\pm 0.01\%$ zero to full load
Note: All accuracies are given as a percentage of span.

Output Ripple: 10 mV P/P maximum
Response Time: Depends on ramp rate & function
Temperature Range: 0° to 140°F (-18° to 60°C)
operating; -40° to 185°F (-40° to 85°C) storage
Power Supply Effect: $\pm 0.05\%$ for a $\pm 10\%$ power variation

Power

115 VAC: 50/60 Hz, 0.7 PF (Standard)	48 VDC: Isolated (Option P3)
12 VDC: Isolated (Option P8)	125 VDC: Isolated (105-140 VDC) (Option P4)
24 VDC: Non-isolated (Option P1)	230 VAC: 50/60 Hz, 0.7 PF (Option P5)
24 VDC: Isolated (Option P2)	

Note: All units 3 watts maximum, and a $\pm 10\%$ power variation unless noted.

Mechanical

Electrical Classification: General purpose
Connection: Barrier terminal strip (3/8" spacing, No. 6 screws)
Controls: Multiturn zero, span, and time-constant controls
Mounting: Surface mounting standard. See Housings Section for options.
Weight: Net Unit: 2.6 pounds (1.18 kilograms); Shipping: 3.0 pounds (1.36 kilograms)

Options

Option Number	Description
I 18	Low impedance DC current inputs (1/10 of standard Z)
O 10	Bipolar current (larger than ± 1 mA)
O 11	Bipolar voltage to ± 10 VDC: at 1 mA, bipolar current ± 1 mA
O 15	Two-wire transmitter excitation
H 10	Thin-line conduit mounting plate and terminal cover
H 13B, H 14B, H 15 B	NEMA 4, 7, and 12 enclosures
H 16	PFA 12 high-density, plug-in enclosure

Ordering Information

- Model number
- Input signal
- Time constant
- Output signal
- Prime power with option no.
- Input/output options
- Housing and miscellaneous options

Please refer to the Housing and/or Option Section for more specific and detailed information.

Represented by:



Analog-Digital Technology, Inc.
3750 Monroe Avenue
Pittsford, New York 14534-1302
Phone: (716) 383-8280
Fax: (716) 383-8386
E Mail: adtech@adtech-inst.com
Web site: http://www.adtech-inst.com

Information subject to change without notice.