



**ADTECH**  
Analog-Digital Technology, Inc.  
3750 Monroe Avenue  
Pittsford, New York 14534-1302  
(716) 383-8280 • FAX (716) 383-8386

# DCA 114 – DCA 115

## DC Current/Voltage Alarms

### Instruction Manual

### 1.0 INTRODUCTION

These instructions refer to the above models. Supplementary sheets are attached if the unit has special options or features. For detailed specifications, refer to the Data Bulletin. All ADTECH instruments are factory calibrated and supplied with a label detailing the calibration. Adjustments are normally not necessary. A simple check should be performed to verify calibration before installation to ensure that it matches the field requirement.

### 2.0 GENERAL DESCRIPTION

The ADTECH DCA 114 and DCA 115 alarms are single and dual alarms that accept a process input signal of 1.25 mvdc to 250 vdc or 0-1 to 0-50 madc.

The DCA 114 is a single alarm providing a DPDT output and the DCA 115 is a dual alarm providing 2 SPDT outputs as standard. DPDT output on DCA 115 is optionally available and requires the "Wide Line" enclosure.

The single alarm may be a Hi or Low alarm; the dual alarm may be Hi-Low, Low-Hi, Hi-Hi or Low-Low. Internal jumpers determine the proper relay(s) action.

The relay coil may be power fail safe (i.e.) energized for normal conditions or NON-power fail safe (i.e.) energizes on abnormal conditions.

Unless otherwise specified, the single alarm is set as Hi trip, power fail safe and the dual alarm as Hi-Low trip, power fail safe.

LED indicator(s) for alarm condition is provided as standard. Green indicates normal condition and red indicates alarm condition.

Power Option P-1 Non-Isolated 24 vdc provides negative input signal and negative DC power common rail connection.

### 3.0 INSTALLATION

The instrument is supplied in a general purpose enclosure as standard. NEMA 4, 7 or 12 and plug in chassis enclosures are optionally available. Installation area/location must agree with the supplied instruments including operating temperature and ambient conditions.

#### Mounting

Refer to the appropriate outline drawing for mounting and clearance dimensions. The instrument is surface mounted with two #10-32 screws on 8.00 inch centers.

#### Electrical Connections

The wire used to connect the instrument to the control system **Input/Output** should be a twisted pair(s) and sized according to normal practice. Shielded cable is not normally necessary (if used, the shield must be grounded at the input negative of the ADTECH instrument and left floating at the sensor).

A 12 position barrier terminal block with #6-32 screws and

3/8" spacing is provided for **IO** and power connection. A housing ground terminal marked G is also provided.

#### Controls

Internal ZERO and SPAN controls are provided for fine ZERO and SPAN calibration. External multiturn trip set controls are provided to set the trip point(s) level on all units. Adjustable deadband and adjustable time delay control(s) may also be provided if specified. If optional calibrated dial(s) for trip set and/or adjustable deadband control(s) is supplied, they are normally mounted in the "Wide Line" enclosure.

The external multiturn control(s) is accessible through the instrument front panel and are clearly marked for ease of use.

### 4.0 MAINTENANCE

These instruments are electronic except for the relay outputs and require no maintenance except for periodic cleaning and calibration verification. The standard relay is rated by the manufacturer for 500,000 10 amp operations at 30 vdc and 2x10<sup>7</sup> mechanical operations. Relay output(s) should be verified at user established time intervals. If the unit appears to be mis-operating it should be checked in place per section 6.0 or removed for a bench check per sections 6.0 and 7.0. MOST problems are traced to field wiring and/or associated circuits. If the problem appears to be within the instrument, proceed to sections 6.0 and 7.0.

### 5.0 CONNECTIONS

Standard connections are shown below and on the instrument face plate, Data Bulletin or on attached supplementary sheets.

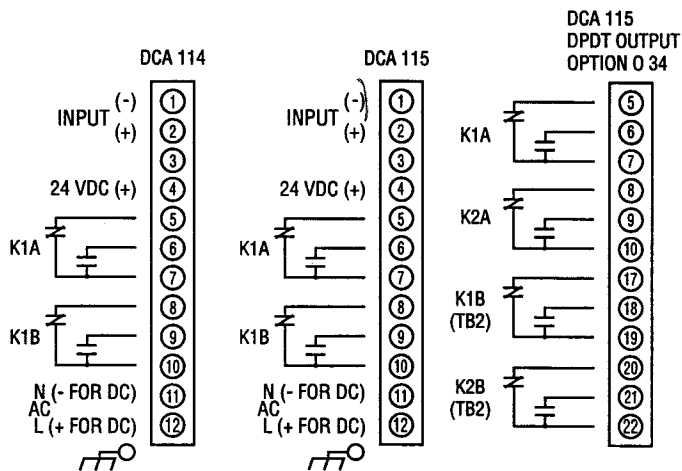

NOTE: All relays are shown in shelf condition

## 6.0 SET UP AND CALIBRATION

All ADTECH units are factory calibrated per your instructions. Usually, a complete recalibration is not required unless it is required to change input types, relay action, or the range of the unit. Most calibrations will only require an alarm SET POINT adjustment and the associated options like adjustable DEAD BAND or TIME DELAY.

The calibration process is broken into 5 separate steps as follows:

Input and Output Configuration .....	Sec 6.1
Determining the MAJOR RANGE setting .....	Sec 6.2
Determining the COARSE ZERO and SPAN settings .....	Sec 6.3
FINE ZERO and SPAN adjustment .....	Sec 6.4
Alarm SET POINT, DEAD BAND, and TIME DELAY adjustment .....	Sec 6.5

## 6.1 INPUT AND OUTPUT CONFIGURATION

### 6.1.1 INPUT CONFIGURATION

The ADTECH Series 100 DC Input alarms, DCA 114/115 interface to both Current and voltage DC waveforms. **IMPORTANT:** refer to the connection diagram for the appropriate connection to the terminal block for voltage or current inputs.

If you are changing your ADTECH supplied (per order) input configuration, Wire Jumpers J1, J2 and J3 may need to be changed in accordance with selecting the Major Range of the unit. Consult the Determining Major Range section in this manual for further details.

### 6.1.2 OUTPUT CONFIGURATION

All ADTECH series 100 alarms allow the customer to change the factory set relay action. The Alarm(s) may be configured for LOW alarm (Alarm condition when the input falls below the set point) or HIGH alarm (Alarm condition when input rises above the set point) as required by your particular application. Table 1 shows the jumper(s) setting required to set the appropriate alarm type.

In addition to the alarm type, the mode in which the relay is energized may be changed. The Relay(s) may be either energized in a FAILSAFE mode (Relay energized under normal, non alarm conditions) or NON-FAILSAFE mode (Relay De-energized under normal, non alarm conditions) as per the application. Use Table 1 to set the jumper(s) as required.

### 6.1.3 COMMON EXAMPLES

Example 1 – Single Alarm (K1), High Alarm and Failsafe.

- Jumper J03 set to position A, sets the High Alarm type for relay K1.
- Jumper J01 set to position A, sets the relay to be energized in the Failsafe Mode.

Example 2 – Dual Alarm (K1 and K2), K1 – High Alarm and Failsafe; K2 – Low Alarm and Failsafe.

- Jumper J03 set to position A, sets the High Alarm type for relay K1.
- Jumper J01 set to position A, sets the Relay K1 to be energized in the Failsafe Mode.
- Jumper J04 set to position B, sets the LOW Alarm type for relay K2.
- Jumper J02 set to position A, sets the Relay K2 to be energized in the Failsafe Mode.

## 6.2 DETERMINING MAJOR RANGE

The ADTECH 100 Series of Alarms is designed to provide a wide input range compatibility. This is accomplished with a technique that first conditions the input to a MAJOR RANGE. This ranging technique assures the highest performance from our units and maintains a standard, easy to use calibration method. You can then elevate or suppress up to 85% of the MAJOR RANGE with the COARSE ZERO settings, and also scale to less than 15% of the MAJOR RANGE with the COARSE SPAN settings. The FINE ZERO and SPAN controls provide 12% adjustment of the MAJOR RANGE.

The input SPAN and ZERO values are used to select the MAJOR RANGE from table 4. The MAJOR RANGE is determined from the larger of the SPAN, or ZERO x 1.17 (ignoring the sign) as per the following examples.

Example 1: 1 – 5 vdc

$$\text{SPAN} = 1 - 5 = 4$$

$$\text{ZERO} = (1) \times 1.17 = 1.17$$

Span dominates the selection in this case. You would select the MAJOR RANGE that is greater than or equal to 4vdc from table 4 (selected value 5.12 vdc).

Example 2: Input of 1 to 1.5 vdc

$$\text{SPAN} = (1.5 - 1) = 0.5 \text{ vdc}$$

$$\text{ZERO} = 1 \times 1.17 = 1.17$$

This example shows the selection based on the ZERO value. From table 6, you would select a MAJOR RANGE of 5.12v.

## 6.3 COARSE ZERO AND SPAN SETTINGS

Once the MAJOR RANGE is selected, one can determine the COARSE ZERO and SPAN settings. The procedure involves dividing both the ZERO and SPAN values by the MAJOR RANGE to determine a percentage. Then look up the proper settings from tables 2 and 3. We will use values from the first example above to illustrate the procedure.

Example 1: Input of 1 to 5 vdc

$$\text{SPAN of } (5 - 1) = 4$$

$$\text{ZERO of } 1 \times 1.17 = 1.17$$

$$\text{MAJOR RANGE of } 5.12 \text{ vdc}$$

$$\% \text{SPAN of MAJOR RANGE } 4/5.12 \times 100\% = 78.1\%$$

$$\% \text{ZERO of MAJOR RANGE } (1.17/5.12) \times 100\% = 19.5\%$$

Simply find the range that includes the percentages you just calculated in the appropriate table.

## 6.4 FINE ZERO AND SPAN ADJUSTMENT

The FINE ZERO and SPAN controls provide an adjustment of 12% of the MAJOR RANGE selected. This is an INTERNAL adjustment. You will need a voltmeter with resolution to 1 mV to do the fine adjustment. The procedure is as follows:

6.41 Connect the voltmeter from GND(–) to VNORM1(+) on the test point header H3 (Refer to figure 2 for locations.) Apply ZERO input to the unit, and adjust the ZERO ADJ. potentiometer until the meter reads 0 Vdc +/- 2 mV.

6.42 Connect the voltmeter from +VR(–) to VNORM1(+) on the test point header. Apply full scale to the unit, and adjust the SPAN ADJ. potentiometer until the meter reads 0 Vdc +/- 2 mV.



