



ADTECH
Analog-Digital Technology, Inc.

The Adtech Model ALM 00 Analog Linearizer Module offers an accurate and economical means of converting whole or fractional power functions into linear outputs such as linear flow outputs from flumes and weirs.

The standard model handles monotonic functions such as root extraction and power functions. The power exponent is adjustable by a single multiturn potentiometer and is non-interactive with the zero or span calibration potentiometers. The value of the power exponent is limited from 0.2 to 5.

Option O 43 provides logarithmic functions on a continuous calculation method, and the output may be the log of input or antilog of input.

The 10-segment breakpoint linearizer, option O 42, provides easy calibration with each segment allowing an increase or decrease of slope with the center position of the potentiometer providing a gain of one. Also available is combined root extraction with breakpoint linearization, which provides better curve linearization.

Zero, span, and other controls are provided by infinite resolution potentiometers. Recalibration to other ranges within the specifications from a current or voltage source to standard process signals such as 4-20 mA DC, 1-5 VDC, or zero-based output is very convenient.

The ALM 00 employs the latest design and components utilizing proven techniques for the utmost in reliability, accuracy, and serviceability.

The ALM 00 provides standard process current or voltage signals on the output with a maximum of 10 mV P/P output ripple. It offers a convenient way of interfacing nonlinear signals to a computer system or other process instrumentation for improved resolution.

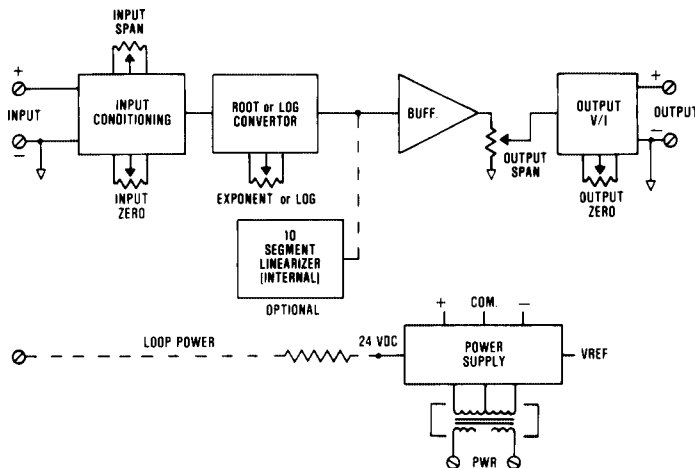

Features

- **Solves:** $x^{3/2}$, $x^{5/2}$, or x^n whole or fractional powers
- **Whole or Fractional Powers:** 0.2 to 5
- **Log or Antilog Conversion**--optional
- **10-segment Linearization**--optional
- **DC Current Inputs:** 4-20 mA, etc.
- **DC Voltage Inputs:** 1-5 VDC, etc.
- **Low Impedance Current Inputs:** 1/10 standard--optional
- **Repeatability:** $\pm 0.02\%$ of span
- **High Accuracy:** $\pm 0.1\%$ of span

Analog Linearizer Module

Model No. ALM 00

Typical Applications

- **Flume, and weir-flow linearization**
- **Logarithmic conversions**
- **Analyzer linearization**
- **PH or ION concentration linearization**
- **Cylindrical or spherical tank volume computation**
- **Density or turbidity linearization**
- **Radiation pyrometer linearization**
- **Signal characterization**



