



**ADTECH**  
Analog-Digital Technology, Inc.

## 300L Series LOW POWER Three-Wire Field Selectable Wide Ranging Transmitters Guide



### Features

- **Types of Inputs:** AC I/V (TRMS or average); frequency, millivolts, potentiometer, RTD, DC I/V, T/C.
- **No Interaction:** Zero and span controls
- **Elevation/Suppression:** Up to 100% of range
- **Power Range:** 7 to 42 VDC, 3.5 mA typical
- **RFI-Resistant**
- **Temperature Coefficients:**  
Zero =  $\pm 0.007\%/^{\circ}\text{C}$  of span—typical  
Span =  $\pm 0.008\%/^{\circ}\text{C}$  of span—typical
- **Repeatability:**  $\pm 0.002\%$  typical
- **Bandwidth:** (-3 db): 3.2 Hz typical
- **Isolation:** 1000 VDC or 600 VAC
- **Power Supply Effect:**  $\pm 0.005\%$  of span
- **Response Time:** 110 milliseconds typical
- **Reverse Polarity Protection**

### Typical Applications

#### Measurement of:

- Temperature
- Flow
- Speed
- Position
- Displacement
- Rotation
- AC Current
- AC Voltage
- DC Signals

## AC Input ACT 340L (Isolated)

### Input/Output

#### Input Signals

**AC Current:** Any 0-1 to 0-5 amps AC, burden less than 0.5 VA (Selectable average or true RMS responding)

**AC Voltage:** Any 0-0.25 to 0-250 VAC, burden less than 0.5 VA (Selectable average or true RMS responding) (4 major ranges 0.25, 2.5, 25, 250)

**Zero Adjustment:** ±5% nominal of span

**Course Span Adjustment:** 100% of a major range (voltage only)

**Fine Span Adjustment:** ±5% nominal of major range (±1 Amp for current input)

**Input Frequency Range:** 25-1,000 Hz

**Input Overload Capability:** 200% continuous

**Output Signals:** 1-5 VDC or 0-5 vdc

**Output Drive Capability:** 10K ohms min.

### Performance

**Calibrated Accuracy:** ±0.25%

**Independent Linearity:** ±0.15% maximum, ±0.06% typical

**Repeatability:** ±0.005% max., ±0.002% typ.

**Zero TC:** ±0.01% of span max/°C

**Span TC:** ±0.02% of span max/°C

**Load Effect:** ±0.005% zero to full load

**Output Ripple:** 10 mV P/P maximum

**Response Time:** 350 milliseconds (10 to 90% step response) average responding

**Bandwidth:** (-3 db): 1 Hz

**Temperature Range:**

-25° to 185°F (-31° to 85°C) operating;

-40° to 200°F (-40° to 93°C) storage

**Power Supply Effect:** ±0.005% of span, max.

**Isolation:** Input/output/case: 1000VDC or 600VAC

*Note: All accuracies are given as a % of span.*

### Power

7 to 42 VDC: 3.5 mA typical; 5 mA maximum

### Mechanical

**Electrical Classification:** General purpose

**Connection:** Screw, compression type, accepts up to 14 AWG

**Controls:** One 16-position rotary switch for course span; two multiturn potentiometers for fine zero and span control, jumpers for measurement response type TRMS or average and for input ranges and output selection

**Mounting:** DIN rails, Surface, snap-track, or NEMA 4 or 7

**Weight:** Net Unit: 4 oz. (115 grams);

**Shipping:** Nominal 7 oz. (200 grams)

### Options

H 15 D, H 25 – H 30 Mounting

## Frequency Input FDT 350L (Isolated)

### Input/Output

#### Input Signals

**Voltage (Amplitude):** 10 mV-100 Vrms (0-5 kHz); 50 mV to 50 Vrms (5 kHz to 30 kHz)

**Contact:** Dry, 2 mA @ 24 VAC rating

**Frequency Range:** 0-30 Hz to 0-30 kHz full scale

**Major Range Switch:** Provides 11 discrete ranges with the zero control adjustable 10% of output and span control adjustable from 50% to 100% of the major range selected

**Output Signals:** 1-5 VDC or 0-5 VDC

**Output Drive Capability:** 10K ohms min.

### Performance

**Calibrated Accuracy:** ±0.1%

**Independent Linearity:** ±0.02% max.; ±0.01% typical

**Repeatability:** ±0.005% max., ±0.002% typ.

**Zero TC:** ±0.01% of span max/°C

**Span TC:** ±0.01% of span max/°C

**Load Effect:** ±0.005% zero to full load

**Output Ripple:** 10 mV P/P maximum

**Response Time:** 350 milliseconds (10 to 90% step response)

**Bandwidth:** (-3 db): 1 Hz

**Temperature Range:**

-25° to 185°F (-31° to 85°C) operating;

-40° to 200°F (-40° to 93°C) storage

**Power Supply Effect:** ±0.005% of span, max.

**Isolation:** Input/output/case: 1000 VDC or 600 VAC

*Note: All accuracies are given as a % of span.*

### Power

7 to 42 VDC: 3.5 mA typical; 5 mA maximum

### Mechanical

**Electrical Classification:** General purpose

**Connection:** Screw, compression type, accepts up to 14 AWG

**Controls:** One 16 position rotary switch for major range; four multiturn potentiometers for zero, span, hysteresis and sensitivity and jumpers for output selection

**Mounting:** DIN rails, Surface, snap-track, or NEMA 4 or 7

**Weight:** Net Unit: 4 oz. (115 grams);

**Shipping:** Nominal 7 oz. (200 grams)

### Options

H 15 D, H 25 – H 30 Mounting

## MV Input MVT 306L (Non-Isolated)

### Input/Output

#### Input Signals

**0.5 mV to 100 mV span** (Z in greater than 10 megohms)

**Zero Suppression:** Up to 100% of the major range selected in 16 divisions of the coarse zero adjustment switch

**Span:** From 0.5 mV to 100 mV full scale switch selectable. The coarse span switch adds 16 divisions to each major range.

**Output Signals:** 1-5 VDC or 0-5 VDC

**Output Drive Capability:** 10K ohms min.

### Performance

**Calibrated Accuracy:** ±0.1%

**Independent Linearity:** ±0.01% maximum, ±0.006% typical (14-bit digital linearity)

**Repeatability:** ±0.005% max., ±0.002% typ.

**Zero TC:**  $\pm \left( \frac{0.025}{\text{input span (mV)}} + 0.005 \right)$  % of span max./°C

**Span TC:** ±0.008% of span max/°C

**Load Effect:** ±0.005% zero to full load

**Output Ripple:** 10 mV P/P maximum

**Response Time:** 110 milliseconds (10 to 90% step response)

**Bandwidth:** (-3 db): 3.2 Hz

**Temperature Range:**

-25° to 185°F (-31° to 85°C) operating;

-40° to 200°F (-40° to 93°C) storage

**Power Supply Effect:** ±0.005% of span, max.

*Note: All accuracies are given as a % of span.*

### Power

7 to 42 VDC: 3.5 mA typical; 5 mA maximum

### Mechanical

**Electrical Classification:** General purpose

**Connection:** Screw, compression type, accepts up to 14 AWG

**Controls:** Two 16 position rotary switches for coarse zero and span control; two multiturn potentiometers for fine zero, span control and jumpers for major range; zero elevation and output selection

**Mounting:** DIN rails, Surface, snap-track, or NEMA 4 or 7

**Weight:** Net Unit: 4 oz. (115 grams);

**Shipping:** Nominal 7 oz. (200 grams)

### Options

H 15 D, H 25 – H 30 Mounting

## MV Input MVT 326L (Isolated)

### Input/Output

#### Input Signals

**0.5 mV to 100 mV span** (Z in greater than 10 megohms)

**Zero Suppression:** Up to 100% of the major range selected in 16 divisions of the coarse zero adjustment switch

**Span:** From 0.5 mV to 100 mV full scale switch selectable. The coarse span switch adds 16 divisions to each major range.

**Output Signals:** 1-5 VDC or 0-5 VDC  
**Output Drive Capability:** 10K ohms min.

### Performance

**Calibrated Accuracy:** ±0.1%

**Independent Linearity:** ±0.01% maximum, ±0.006% typical (14-bit digital linearity)

**Repeatability:** ±0.005% max., ±0.002% typ.

**Zero TC:**  $\pm \left( \frac{0.025}{\text{input span (mV)}} + 0.005 \right)$   
% of span max./°C

**Span TC:** ±0.008% of span max./°C

**Load Effect:** ±0.005% zero to full load

**Output Ripple:** 10 mV P/P maximum

**Response Time:** 110 milliseconds (10 to 90% step response)

**Bandwidth:** (-3 db): 3.2 Hz

#### Temperature Range:

-25° to 185°F (-31° to 85°C) operating;

-40° to 200°F (-40° to 93°C) storage

**Power Supply Effect:** ±0.005% of span, max.

**Isolation:** Input/output/case: 1000 VDC, or 600 VAC

*Note: All accuracies are given as a % of span.*

### Power

**7 to 42 VDC:** 3.5 mA typical, 5 mA maximum

### Mechanical

**Electrical Classification:** General purpose

**Connection:** Screw, compression type, accepts up to 14 AWG

**Controls:** Two 16 position rotary switches for coarse zero and span control; two multiturn potentiometers for fine zero and span control and jumpers for major range; zero elevation and output selection

**Mounting:** DIN rails, Surface, snap-track, or NEMA 4 or 7

**Weight:** Net Unit: 4 oz. (115 grams);

**Shipping:** Nominal 7 oz. (200 grams)

### Options

**H 15 D, H 25 – H 30** Mounting

## Potentiometer Input PTT 373L (Non-Isolated)

### Input/Output

#### Input Signals

**Potentiometers/Slidewire Sensors:** 3 Wire  
**50 ohm to 100 k ohm Resistance Spans**

Standard

**Zero Suppression:** Up to 100% of the potentiometer rotation selected in 16 divisions of the coarse zero adjustment switch.

**Span:** From 0-100% full scale switch selectable. The coarse span switch adds 16 range divisions.

**Output Signals:** 1-5 VDC or 0-5 VDC  
**Output Drive Capability:** 10K ohms min.

### Performance

**Calibrated Accuracy:** ±0.1%

**Independent Linearity:** ±0.01% maximum, ±0.006% typical (14-bit digital linearity)

**Repeatability:** ±0.005% max., ±0.002% typ.

**Zero TC:** ±0.007% of span max./°C

**Span TC:** ±0.010% of span max./°C

**Load Effect:** ±0.005% zero to full load

**Output Ripple:** 10 mV P/P maximum  
**Response Time:** 110 milliseconds (10 to 90% step response)

**Bandwidth:** (-3 db): 3.2 Hz

#### Temperature Range:

-25° to 185°F (-31° to 85°C) operating;

-40° to 200°F (-40° to 93°C) storage

**Power Supply Effect:** ±0.005% of span, max.

*Note: All accuracies are given as a % of span.*

### Power

**7 to 42 VDC:** 3.5 mA typical, 5 mA maximum

### Mechanical

**Electrical Classification:** General purpose

**Connection:** Screw, compression type, accepts up to 14 AWG

**Controls:** Two 16 position rotary switches for coarse zero and span control; two multiturn potentiometers for fine zero and span control and jumpers for output selection

**Mounting:** DIN rails, Surface, snap-track, or NEMA 4 or 7

**Weight:** Net Unit: 4 oz. (115 grams);

**Shipping:** Nominal 7 oz. (200 grams)

### Options

**H 15 D, H 25 – H 30** Mounting

## RTD Input RBT 374L (Non-Isolated)

### Input/Output

#### Input Signals

**Resistance Bulb Sensor:** 2,3, or 4 wire types  
**1 to 400 ohm Resistance Spans:** Standard

**Zero Suppression:** Up to 100% of the major range selected in 16 divisions of the coarse zero adjustment switch.

**Span:** From 0-100% full scale switch selectable. The coarse span switch adds 16 divisions to each major range.

**Lead Compensation:** 1% maximum error, of differential lead resistance.

**Output Signals:** 1-5 VDC or 0-5 VDC  
**Output Drive Capability:** 10K ohms min.

### Performance

**Calibrated Accuracy:** ±0.1%

**Independent Linearity:** ±0.025% max., ±0.01% typical

**Conformance to RTD Curves:** 0.15% max.

**Repeatability:** ±0.005% max., ±0.002% typ.

**Zero TC:**  $\pm \left( \frac{0.05}{\text{input span (ohms)}} + 0.005 \right)$   
% of span/°C max.

**Span TC:** ±0.008% of span max./°C

**Load Effect:** ±0.005% zero to full load

**Output Ripple:** 10 mV P/P maximum

**Response Time:** 110 milliseconds (10 to 90% step response)

**Bandwidth:** (-3 db): 3.2 Hz

#### Temperature Range:

-25° to 185°F (-31° to 85°C) operating;

-40° to 200°F (-40° to 93°C) storage

**Power Supply Effect:** ±0.005% of span, max.

*Note: All accuracies are given as a % of span.*

### Power

**7 to 42 VDC:** 3.5 mA typical, 5 mA maximum

### Mechanical

**Electrical Classification:** General purpose

**Connection:** Screw, compression type, accepts up to 14 AWG

**Controls:** Two 16 position rotary switches for coarse zero and span control; two multiturn potentiometers for fine zero and span control and jumpers for RTD type, major range, input zero elevation and output selection

**Mounting:** DIN rails, Surface, snap-track, or NEMA 4 or 7

**Weight:** Net Unit: 4 oz. (115 grams);

**Shipping:** Nominal 7 oz. (200 grams)

### Options

**H 15 D, H 25 – H 30** Mounting

## RTD Input RBT 372L (Isolated)

### Input/Output

#### Input Signals

**Resistance Bulb Sensor:** 2,3, or 4 wire types  
**1 to 400 ohm Resistance Spans:** Standard  
**Zero Suppression:** Up to 100% of the major range selected in 16 divisions of the coarse zero adjustment switch.  
**Span:** From 0-100% full scale switch selectable. The coarse span switch adds 16 divisions to each major range.  
**Lead Compensation:** 1% maximum error, of differential lead resistance.

**Output Signals:** 1-5 VDC or 0-5 VDC  
**Output Drive Capability:** 10K ohms min.

### Performance

**Calibrated Accuracy:**  $\pm 0.1\%$   
**Independent Linearity:**  $\pm 0.025\%$  max.,  $\pm 0.01\%$  typical  
**Conformance to RTD Curves:** 0.15% max.  
**Repeatability:**  $\pm 0.005\%$  max.,  $\pm 0.002\%$  typ.  
**Zero TC:**  $\pm \left( \frac{0.05}{\text{input span (ohms)}} + 0.005 \right)$   
% of span/ $^{\circ}\text{C}$  max.  
**Span TC:**  $\pm 0.008\%$  of span max./ $^{\circ}\text{C}$   
**Load Effect:**  $\pm 0.005\%$  zero to full load  
**Output Ripple:** 10 mV P/P maximum  
**Response Time:** 110 milliseconds (10 to 90% step response)  
**Bandwidth:** (-3 db): 3.2 Hz  
**Temperature Range:**  
-25 $^{\circ}$  to 185 $^{\circ}\text{F}$  (-31 $^{\circ}$  to 85 $^{\circ}\text{C}$ ) operating;  
-40 $^{\circ}$  to 200 $^{\circ}\text{F}$  (-40 $^{\circ}$  to 93 $^{\circ}\text{C}$ ) storage  
**Power Supply Effect:**  $\pm 0.005\%$  of span, max.  
**Isolation:** Input/output/case: 1000VDC, or 600 VAC  
*Note: All accuracies are given as a % of span.*

### Power

7 to 42 VDC: 3.5 mA typical, 5 mA maximum

### Mechanical

**Electrical Classification:** General purpose  
**Connection:** Screw, compression type, accepts up to 14 AWG  
**Controls:** Two 16 position rotary switches for coarse zero and span control; two multiturn potentiometers for fine zero and span control and jumpers for RTD type, major range, input zero elevation and output selection  
**Mounting:** DIN rails, Surface, snap-track, or NEMA 4 or 7  
**Weight:** Net Unit: 4 oz. (115 grams);  
**Shipping:** Nominal 7 oz. (200 grams)

### Options

H 15 D, H 25 – H 30 Mounting

## I/V/MV Input SCT 302L (Isolated)

### Input/Output

#### Input Signals

**4-20 mA DC** (z in 10 ohms)  
**0-20 or  $\pm 20$  mA DC** (z in 10 ohms)  
**0-10 or  $\pm 10$  mA DC** (z in 20 ohms)  
**0-1 or  $\pm 1$  mA DC** (z in 200 ohms)  
**1-5 VDC** (z in 1 megohm)  
**0-5 or  $\pm 5$  VDC** (z in 1 megohm)  
**0-10 or  $\pm 10$  VDC** (z in 1 megohm)  
Any unipolar or bipolar voltage from 100 MV to 200 VDC. (Option I 14)  
**Zero Suppression:**  $\pm 10\%$   
**Span Adjustment:**  $\pm 10\%$

**Output Signals:** 1-5 VDC or 0-5 VDC  
**Output Drive Capability:** 10K ohms min.

### Performance

**Calibrated Accuracy:**  $\pm 0.1\%$   
**Independent Linearity:**  $\pm 0.025\%$  max.,  $\pm 0.01\%$  typical  
**Repeatability:**  $\pm 0.005\%$  max.,  $\pm 0.002\%$  typ.  
**Zero TC:**  $\pm 0.007\%$  of span max./ $^{\circ}\text{C}$   
**Span TC:**  $\pm 0.008\%$  of span max./ $^{\circ}\text{C}$   
**Load Effect:**  $\pm 0.005\%$  zero to full load  
**Output Ripple:** 10 mV P/P maximum  
**Response Time:** 110 milliseconds (10 to 90% step response)  
**Bandwidth:** (-3 db): 3.2 Hz  
**Temperature Range:**  
-25 $^{\circ}$  to 185 $^{\circ}\text{F}$  (-31 $^{\circ}$  to 85 $^{\circ}\text{C}$ ) operating;  
-40 $^{\circ}$  to 200 $^{\circ}\text{F}$  (-40 $^{\circ}$  to 93 $^{\circ}\text{C}$ ) storage  
**Power Supply Effect:**  $\pm 0.005\%$  of span, max.  
**Isolation:** Input/output/case: 1000 VDC or 600 VAC  
*Note: All accuracies are given as a % of span.*

### Power

7 to 42 VDC: 3.5 mA typical, 5 mA maximum

### Mechanical

**Electrical Classification:** General purpose  
**Connection:** Screw, compression type, accepts up to 14 AWG  
**Controls:** 8 jumpers for ranges; two multiturn potentiometers for fine zero, span  
**Mounting:** DIN rails, Surface, snap-track, or NEMA 4 or 7  
**Weight:** Net Unit: 4 oz. (115 grams);  
**Shipping:** Nominal 7 oz. (200 grams)

### Options

I 14 Voltage/current inputs  
H 15 D, H 25 – H 30 Mounting

## T/C Input TCT 326L (Isolated)

### Input/Output

#### Input Signals

**\*Thermocouple:** All standard ISA calibration (B, E, J, K, R, S, T), -20 mV to 100 mV spans (Z in greater than 1 megohm)  
**Zero Suppression:** Up to 100% of the major range selected in 16 divisions of the coarse zero adjustment switch.  
**Span:** From 0.5 mV to 100 mV full scale switch selectable. The coarse span switch adds 16 divisions to each major range.  
**Upscale/Downscale Burnout Protection:** Standard, field selectable  
**Burnout Current:** 0.1 micro amperes--nominal  
*\*Consult factory for other T/C types.*

**Output Signals:** 1-5 VDC or 0-5 VDC  
**Output Drive Capability:** 10K ohms min.

### Performance

**Calibrated Accuracy:**  $\pm 0.1\%$  (of mv input)  
**Independent Linearity:**  $\pm 0.01\%$  max.,  $\pm 0.006\%$  typical (14-bit digital linearity) (of millivolt input)  
**Repeatability:**  $\pm 0.005\%$  max.,  $\pm 0.002\%$  typ.  
**Zero TC:**  $\pm \left( \frac{0.025}{\text{input span (MV)}} + 0.007 \right)$   
% of span/ $^{\circ}\text{C}$  max.  
**Span TC:**  $\pm 0.008\%$  of span max./ $^{\circ}\text{C}$   
**Load Effect:**  $\pm 0.005\%$  zero to full load  
**Output Ripple:** 10 mV P/P maximum  
**Response Time:** 110 milliseconds (10 to 90% step response)  
**Bandwidth:** (-3 db): 3.2 Hz  
**Temperature Range:**  
-25 $^{\circ}$  to 185 $^{\circ}\text{F}$  (-31 $^{\circ}$  to 85 $^{\circ}\text{C}$ ) operating;  
-40 $^{\circ}$  to 200 $^{\circ}\text{F}$  (-40 $^{\circ}$  to 93 $^{\circ}\text{C}$ ) storage  
**Power Supply Effect:**  $\pm 0.005\%$  of span, max.  
**Isolation:** Input/output/case, 1000 VDC, or 600 VAC  
**Cold Junction Compensation Error:** 1.5 $^{\circ}\text{C}$  max (0 to 50 $^{\circ}\text{C}$ )  
*Note: All accuracies are given as a % of span.*

### Power

7 to 42 VDC: 3.5 mA typical, 5 mA maximum

### Mechanical

**Electrical Classification:** General purpose  
**Connection:** Screw, compression type, accepts up to 14 AWG  
**Controls:** Two 16 position rotary switches for coarse zero and span control; two multiturn potentiometers for fine zero and span control and jumpers for T/C type major range; input zero elevation and output selection  
**Mounting:** DIN rails, Surface, snap-track, or NEMA 4 or 7  
**Weight:** Net Unit: 4 oz. (115 grams);  
**Shipping:** Nominal 7 oz. (200 grams)

### Options

H 15 D, H 25 – H 30 Mounting

The ADTECH 300L Low Power Series Three-Wire Transmitters provide mounting efficiency and ease of wiring in a compact DIN package. Their small size makes them ideal for RTU mounting.

Remote monitoring of oil/gas pipelines, water/waste-water facilities, utility substation, laboratory and vehicle testing are a few typical applications.

The units convert most sensor inputs to 1-5 VDC or 0-5 VDC output for interface directly with PLC's, DCS's and process computers.

Most units provide independent linearity equivalent to 14-bit digital accuracy and include user friendly features such as wide ranging and non-interactive zero and span controls.

The compact DIN mounting style allows high density mounting in new or existing field mounted or control panel enclosures.

Standard mounting is DIN Rail. Surface or snap track mounting is provided at no charge. NEMA 4 or 7 are optionally available.

These units are designed for industrial environments. The housing is made of rugged Krilen for protection against corrosion, moisture and dust. Screw compression terminals are provided for positive field connections.

Reverse polarity protection is supplied as standard.

The power range of 7 to 42 VDC; 3.5 mA typical provides low power consumption.

The input/output can be factory set to order as specified (no charge) or reconfigured in the field by simply adjusting switches, multi-turn potentiometers, and plug-in jumpers.

AC to DC or DC to DC instrument power supplies are available. The IPS 2402 AC/DC powers up to 16 units. The IPS 2416 AC/DC or DC/DC powers up to 100 units. DIN, surface, snap track or NEMA mountings are available.

## Connections

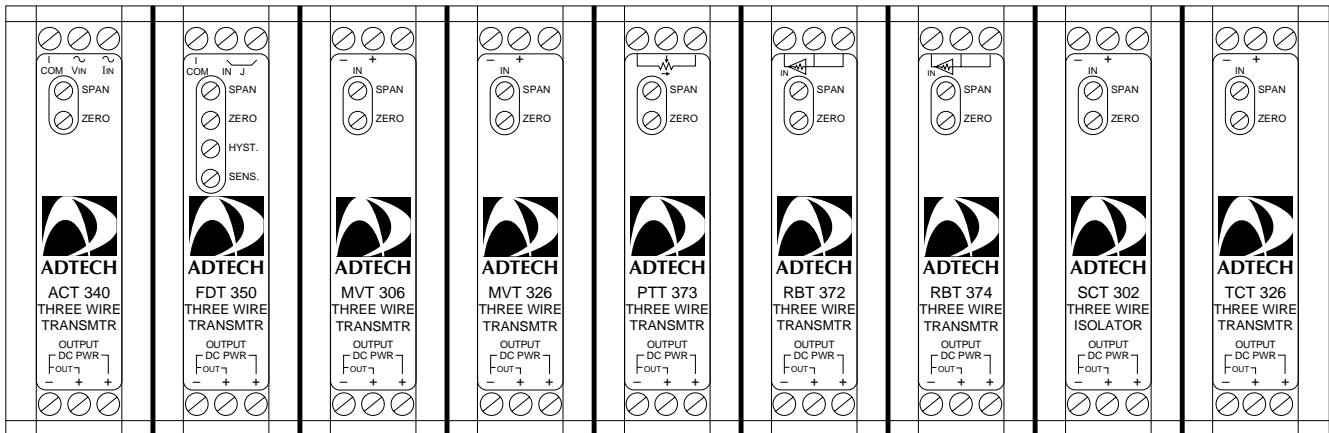

## Typical Connection

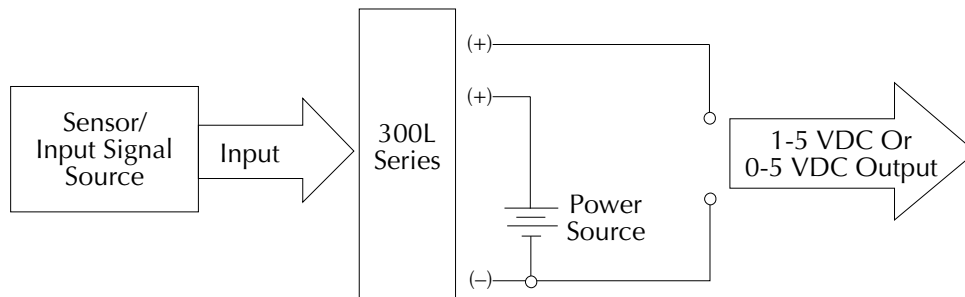

# Outline & Mounting

## DIN Mount (Standard)

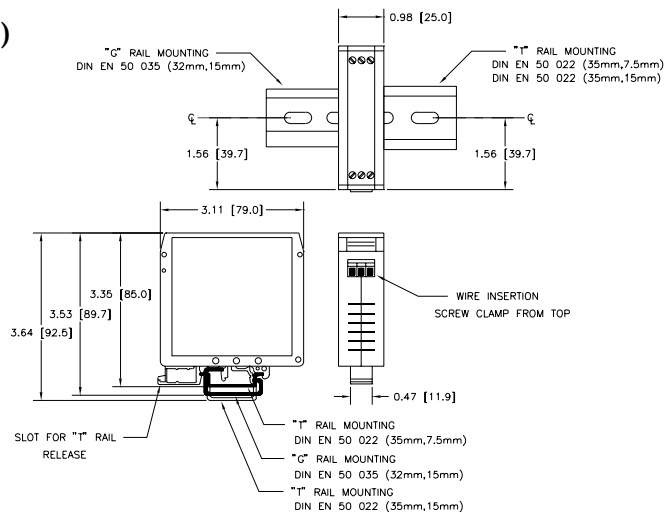

## Snap Track Option H 25

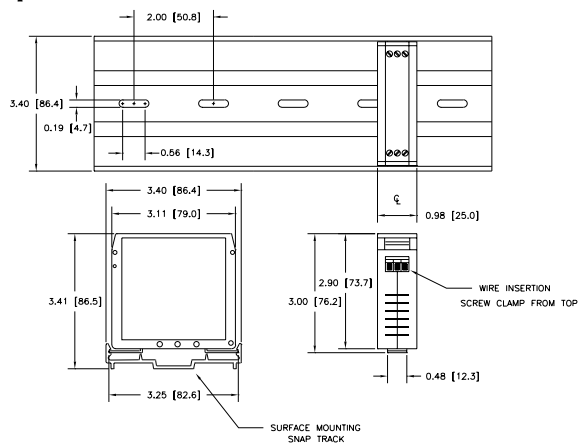

## Surface Option H 26

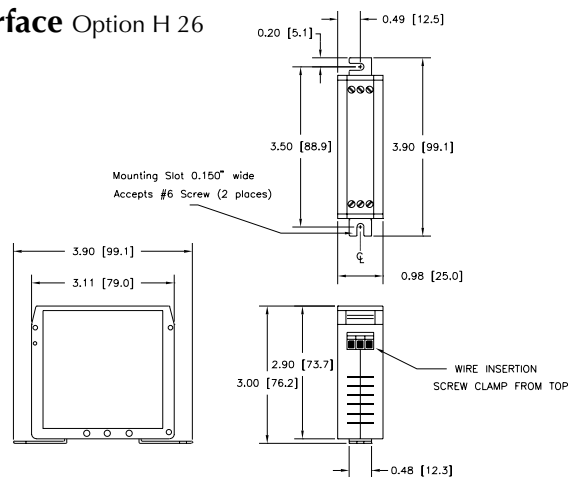

## NEMA 4 Option H 27

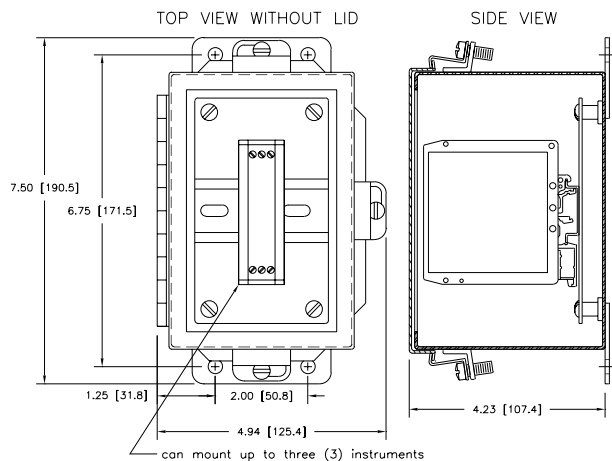

## NEMA 7 Option H15D

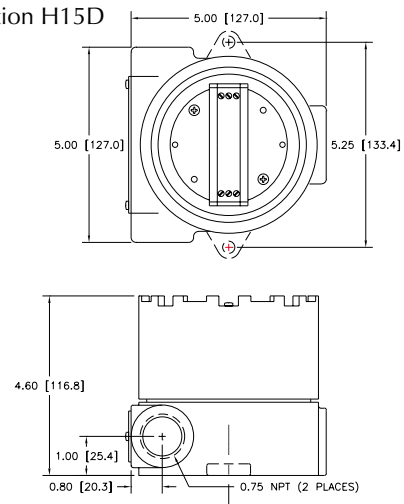

Represented by:



Analog-Digital Technology, Inc.  
830 Canning Parkway  
Victor, New York 14564-8940

Phone: (585) 869-6330  
Fax: (585) 869-1835

E Mail: [adtech@adtech-inst.com](mailto:adtech@adtech-inst.com)  
Web site: <http://www.adtech-inst.com>

Information subject to change without notice.

Printed in U.S.A. A004